



# UNIVERSAL CALIBRATION KIT INSTRUCTION MANUAL

## UCK SERIES

Congratulations! You are the proud owner of a Kele Model UCK calibration kit! This collection of hard-to-find fittings, adapters, and tubing enables connection to a wide variety of gas sensors that Kele sells. In addition, the use of simple inline restrictors and a reliable PG-05 pressure gauge allows the accurate establishment of any desired flow rate from 50 ml/min to 1.0 lpm.

The **Model UCK-1** contains a 51-226AB6610 regulator for non-corrosive gases (N<sub>2</sub>, CO<sub>2</sub>, CH<sub>4</sub>, H<sub>2</sub>, O<sub>2</sub>, CO, refrigerants). The **Model UCK-2** contains a UCKR58 regulator for corrosive gases (NO<sub>2</sub>, H<sub>2</sub>S, SO<sub>2</sub>, NH<sub>3</sub>). The **Model UCK-3** contains both regulators. Gases (ordered separately) are shipped in 17-liter steel cylinders for non-corrosives and 58-liter aluminum cylinders for corrosives.

PARTS INCLUDED (Use part numbers listed to order replacements)	
PART NUMBER	DESCRIPTION
UCKBOX	High-impact poly toolbox
51-226AB6610 (in UCK-1 or UCK-3)	Regulator for 17L gas cylinders (non-corrosives)
UCKR58 (In UCK-2 or UCK-3)	Regulator for 58L gas cylinders (corrosive gases)
UCT2	30" x 3/32" x ID x 5/32" OD tubing, green transparent
UCT3	30" x 1/8" ID x 1/4" OD tubing, red transparent
UCT4	30" x 5/32" ID 9/32" OD tubing, yellow transparent
UCT5	30" x 3/16" ID 5/16" OD tubing, blue transparent
X-B-261	5/32" x 1/4" barbed coupling
X-B-373	1/4" x 1/4" x 1/8" FNPT gauge tee
UCKCAP	1/4" barbed adapter on 1" PVC cap for Figaro® type sensors
UCKGMT	GMT calibration plug adapter
PG-05	30 psig gauge 1/8" MNPT
R-3710-2005	0.005" inline restrictor, 1/4" x 1/4" barbed
R-3710-2007	0.007" inline restrictor, 1/4" x 1/4" barbed
UCKMANUAL	Instruction manual/flow table
X-M-102	1/4" MPT pipe plug
X-B-130	3/16" x 1/8" MPT adapter
X-28-4-4	1/4" barbed x 1/4" MPT
CMD-Calhose Kit	Gas adapter

The tubing and fittings included in the Model UCK were selected to allow easy assembly of an airtight path for calibration gas to flow across the sensing element (or through the sensing chamber) of the full spectrum of gas sensors offered by Kele. Instructions for piping to each of these are included below. In addition, most competitive gas sensors can be rigged for calibration with the Model UCK's five sizes of tubing and assortment of both barbed and special fittings.

**NOTE: This manual is a guide to connecting the included components to various gas sensors, and establishing the sensor manufacturer's recommended gas flow rate. It is not a substitute for the sensor manufacturer's instructions for checking and adjusting calibration in the field. Refer to manufacturer's literature for recommended flow rates, flow durations, and adjustments.**

## GENERAL OPERATION

The **UCK** has gained wide acceptance in the gas sensing market due to its unique method of establishing accurate flow rates of compressed gases at a very low cost. Gas flow rates from 50 milliliters per minute (ml/min or cc/min) to 1 liter per minute (lpm) are specified by the various sensor manufacturers. To cover this range, other calibration methods either rely on the use of a very expensive flow meter for varying rates, or the purchase of multiple fixed-rate orifice style regulators. The **UCK** calibration kit accomplishes the same thing with a standard 1.0 lpm regulator, a **PG-05** pressure gauge, and two conventional inline restrictors in the following fashion:

The regulator supplied with the kit contains an orifice that supplies a fixed flow of 1.0 lpm, provided that there are no significant downstream restrictions that would cause a large (>1 psig) pressure drop at that flow rate. For sensors requiring 1.0 lpm flow, simply connect the blue (3/16" ID) tubing directly to the regulator; then, use appropriate reducers, tubing, and adapters to direct the gas to the sensor in question. Open the regulator valve fully to produce 1.0 lpm flow. Refer to the following section for suggested methods for a number of sensors.

To establish flow rates below 1.0 lpm, connect the **PG-05** pressure gauge and **X-B-373** tee to the regulator with a short (2-3") length of blue (3/16" ID) tubing. Connect one of the inline restrictors (0.005" or 0.007") to the downstream side of the gauge tee with a short (2-3") length of yellow (5/32" ID) tubing. Choose the restrictor based on the table below. Connect to the downstream side of the restrictor with another length of yellow (5/32" ID) tubing; then, use appropriate reducers, tubing, and adapters to direct the gas to the sensor in question (see Diagrams 1 & 2 on pages 3-8). Adjust the regulator valve to supply the desired upstream pressure to the restrictor, and the flow rate in the table below will be produced, again providing that no significant downstream restrictions are present that would cause a large (>1 psig) pressure drop at that flow rate. Refer to the following section for suggested methods for a number of sensors.

**TABLE 2 FLOW TABLE**

UPSTREAM PRESSURE (psig)	0.005" RESTRICTOR FLOW (ml/min)	0.007" F RESTRICTOR FLOW (ml/min)	UPSTREAM PRESSURE (psig)	0.005" RESTRICTOR FLOW (ml/min)	0.007" F RESTRICTOR FLOW (ml/min)
1	50	160	16	220	626
2	78	221	17	227	645
3	95	271	18	233	664
4	110	313	19	240	682
5	123	350	20	246	700
6	135	383	21	252	717
7	146	414	22	258	734
8	156	443	23	264	751
9	165	470	24	269	767
10	174	495	25	275	783
11	182	519	26	280	798
12	191	542	27	286	813
13	198	564	28	291	828
14	206	586	29	296	843
15	213	606	30	300	857

## CONNECTING TO SENSORS

The key to performing an accurate calibration (or check) of a gas sensor is to introduce the calibration gas to the sensing element in a way that prevents mixing with the ambient air and to match the manufacturer's recommended flow rate as closely as possible. This is done by maintaining a calibration gas pressure at the sensor that is very slightly positive with respect to the ambient air. Too much pressure can cause errors since it would tend to increase the number of gas molecules at the sensor. Typically, the manufacturer's recommended flow rates and the connecting fittings are chosen to accomplish this goal. The following connections are specifically related to the types of sensors available from Kele. With a little creativity, UCK components can also be arranged to connect with many other types of sensors.

## TELAIRE 2001 AND 1502 SERIES CO2 SENSORS

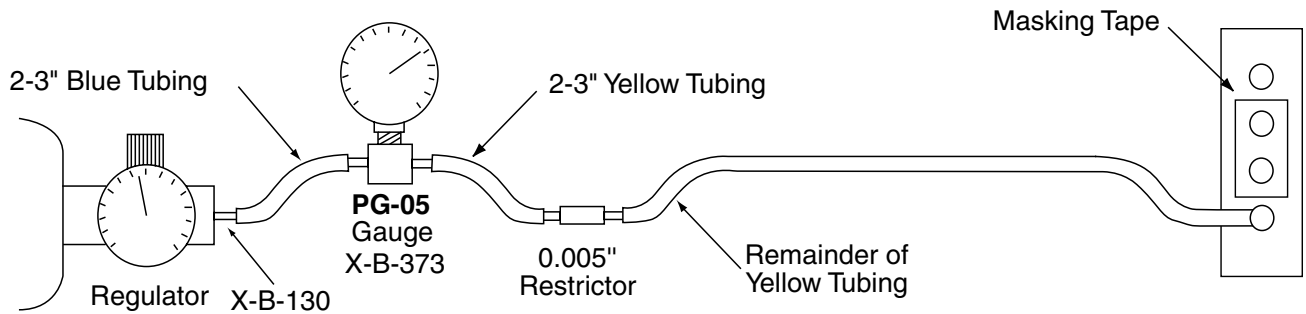

Use the GAS-CO2-2000 along with 171 regulator (51-226AB6610) and X-B-130 along with UCKT4 & 5 tubing, R-3710-2005 resistor, X-B-373 fitting and PG-05 gauge. The 2001V-3 has an optical bench assembly consisting of 9 sensing ports (5 on either side and 4 on the front). It is necessary to mask off all but 2 of the ports on the optical bench assembly with masking tape. Mask off the ports on both sides and mask off the two middle ports on the front of the sensing block, leaving the top and bottom ports on the front open. To connect to the 2001V-3 it is necessary to push the open end of the yellow tubing into one of the two ports that have been covered by the masking tape. This will allow gas flow throughout the optical bench assembly. The fit will be tight, as it needs to be. Do not use any type of lubricant to assist in the working the yellow tubing into the port on the optical bench assembly. The gas flow should be about 200 ml/min or 14 psi on the gauge. Then follow the manufacturer's installation instructions to complete calibration.

## ENGELHARD 7001 AND 8002 SERIES CO2 SENSORS

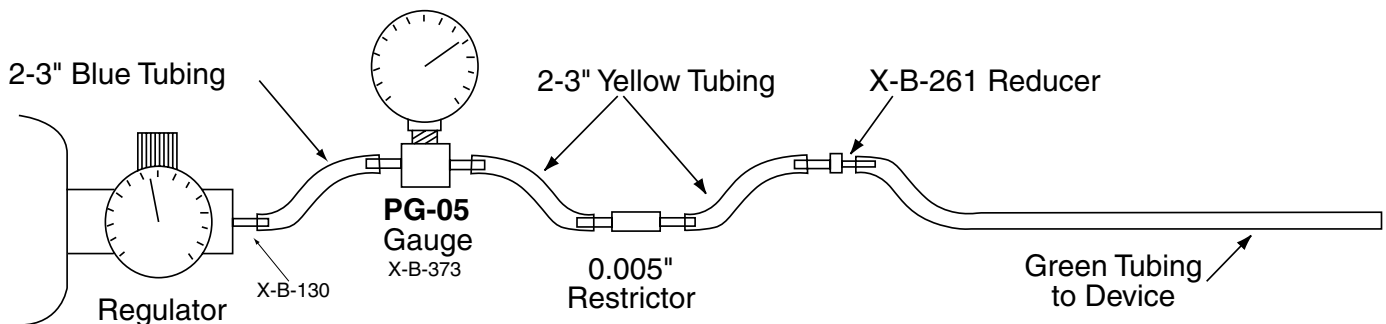

Cut squarely the end of the green (3/32" ID) UCKT2 tubing and insert firmly into the calibration port on the bottom (8002) or back (7001) of the enclosure, until it stays by itself. Use a X-B-261 reducing fitting to connect the other end of the green tubing to a short (2-3") length of yellow (5/32" ID) UCKT4 tubing, which goes to the 0.005" R-3710-2005 restrictor. From the restrictor, connect with a second short (2-3") length of yellow (5/32" ID) tubing to the X-B-373 fitting and attach the PG-05 gauge. From the gauge to the 51-226AB6610 regulator and X-B-130, use a short (2-3") length of blue (3/16" ID) UCKT5 tubing. Adjust flow rates for these products to approximately 80 ml/min (about 2 psig on the PG-05 gauge). Then follow the manufacturer's installation instructions to complete calibration.

**TEXAS INSTRUMENTS 4GS SERIES CO2 SENSORS**

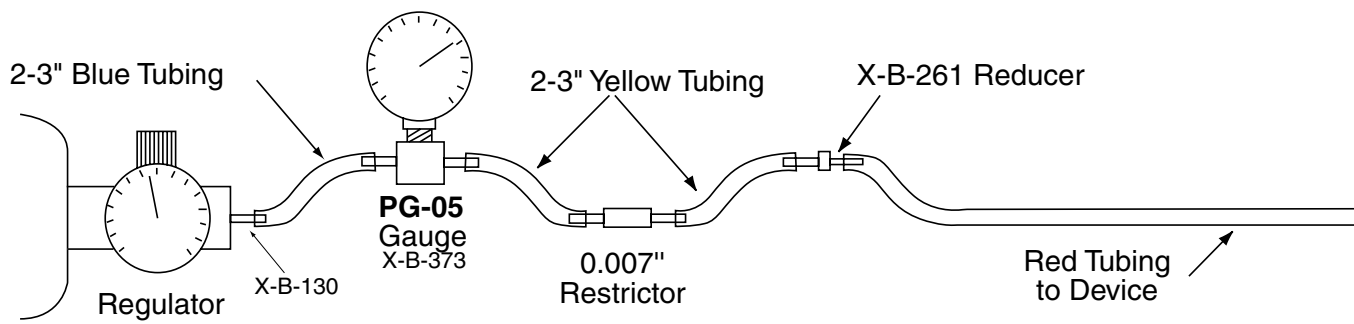

Remove the cap from the calibration gas connection at the bottom of the enclosure. Connect to the sensor with the red (1/8" ID) UCKT3 tubing. Use a X-B-261 reducing fitting to connect the red tubing to a short (2-3") length of yellow (5/32" ID) UCKT4 tubing, then to the 0.007" R-3710-2007 restrictor. Use a second short (2-3") length of yellow (5/32" ID) tubing from the restrictor to the X-B-373 and attach the PG-05 gauge. From the gauge to the 51-226AB6610 regulator and X-B-130, use a short (2-3") length of blue (3/16" ID) UCKT5 tubing. Adjust flow rates for these products to approximately 500 ml/min (about 10 psig on the PG-05 gauge). Then follow the manufacturer's installation instructions to complete calibration.

**KELE CD-1W/CD-AW CO2 SENSORS**

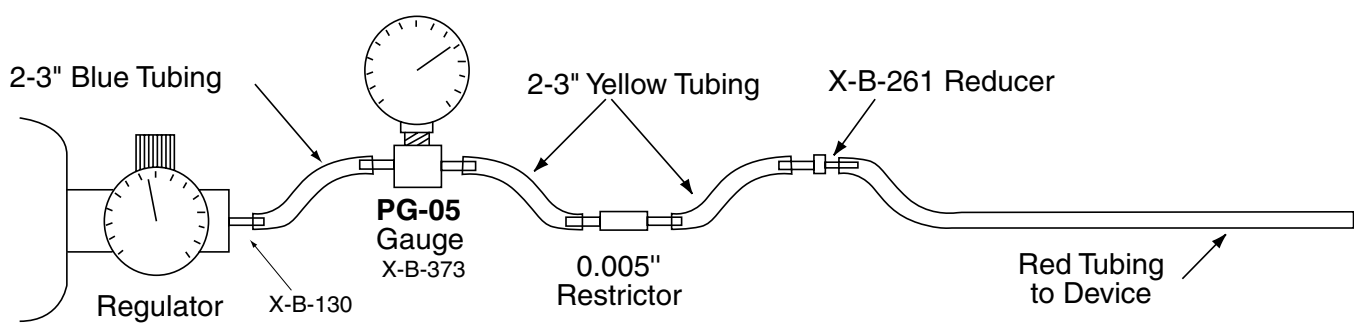

With the sensor open, remove the cap from the calibration gas connection on the side of the optical chamber. Connect to the sensor with the red (1/8" ID) UCKT3 tubing. Use a X-B-261 reducing fitting to connect to a short (2-3") length of yellow (5/32" ID) UCKT4 tubing, then to the 0.005" R-3710-2005 restrictor. Use another short (2-3") length of yellow (5/32" ID) tubing from the restrictor to the X-B-373 fitting and attach the PG-05 gauge. From the gauge to the 51-226AB6610 regulator and X-B-130 use a short (2-3") length of blue (3/16" ID) UCKT5 tubing. Adjust flow rates for these products to approximately 100 ml/min (about 4 psig on the PG-05 gauge). Then follow the manufacturer's installation instructions to complete calibration.

**KELE CD-1D/CD-AD CO2 SENSORS**

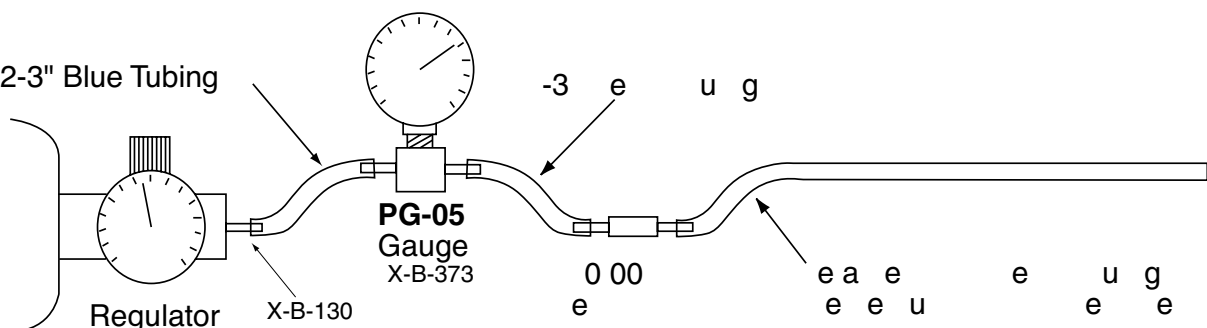

Use a short (2-3") length of blue (3/16" ID) UCKT5 tubing from the 51-226AB6610 regulator and X-B-130 to the X-B-373 fitting and attach the PG-05 gauge, then a short (2-3") length of yellow (5/32" ID) UCKT4 tubing to the 0.005" R-3710-2005 restrictor. Connect from the restrictor to either of the duct ports on the base of the CD-1D with the remainder of the yellow (5/32" ID) tubing. Adjust flow rates for these products to approximately 100 ml/min (about 4 psig on the PG-05 gauge). Then follow the manufacturer's installation instructions to complete calibration.

## KELE GMT SERIES TOXIC / COMBUSTIBLE GAS SENSORS

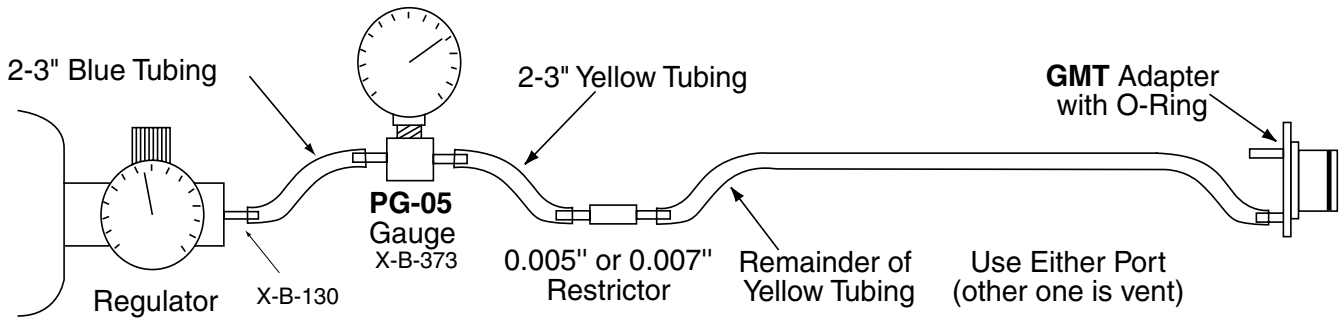

Use a short (2-3") length of blue (3/16" ID) UCKT5 tubing from the regulator (Either 51-226AB6610 and X-B-130 or UCKR58) to the X-B-373 fitting and attach the PG-05 gauge, then a short (2-3") length of yellow (5/32" ID) UCKT4 tubing to either the 0.005/7" R-3710-2005/7 restrictor depending on the flow rate required (see Table 3 below). Connect the remainder of the yellow (5/32" ID) tubing from the restrictor to either of the ports on the GMT adapter (gray disk with two ports and an O-ring). Plug the adapter into the mating recess on the front cover of the GMT, or at the sensor end in an explosion proof GMT. Adjust flow rates for these products to the recommended values for the gas in question, as shown below. For gases not shown, contact a Kele Technical Sales Representative for additional information. Then follow the manufacturer's installation instructions to complete calibration.

### FLOW TABLE

GAS	FLOW RATE (ml/min)	RESTRICTOR/UPSTREAM PRESSURE
Carbon monoxide (CO) - S1	500	0.007" - 10 psig
Carbon monoxide (CO) - S2	80	0.005" - 2 psig
Nitrogen dioxide (NO2) - S1	500	0.007" - 10 psig
Hydrogen (H2) - S1	500	0.007" - 10 psig
Hydrogen (H2) - S2	80	0.005" - 2 psig
Chlorine (Cl2) - S1	1000	(no restrictor)
Combustibles - S2	500	0.007" - 10 psig
Ammonia (NH3) - S1	80	0.005" - 2 psig
Ammonia (NH3) - S2	1000	(no restrictor)
Hydrogen sulfide (H2S) - S1	80	0.005" - 2 psig
Hydrogen sulfide (H2S) - S2	1000	(no restrictor)
Oxygen (O2) - S1	80	0.005" - 2 psig
Sulfur dioxide (SO2) - S1	500	0.007" - 10 psig

## KELE RLD-IR SERIES INFRARED REFRIGERANT LEAK DETECTORS

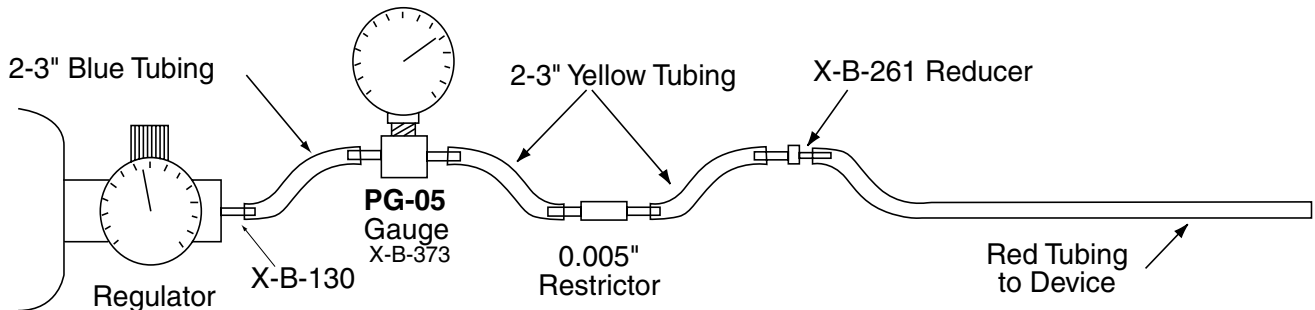

Open the front door of the RLD-IR and connect the red (1/8" ID) UCKT3 tubing to the barbed connector in the bottom of the housing (on the end of the tube coming from the optical chamber). Use the X-B-261 reducing coupling to connect with short (2-3") length of yellow (5/32" ID) UCKT4 tubing to the 0.005" R-3710-2005 restrictor. Connect the restrictor to the X-B-373 fitting and attach the PG-05 gauge with a second short (2-3") length of yellow (5/32" ID) tubing. From the gauge to the 51-226AB6610 regulator and X-B-130, use a short (2-3") length of blue (3/16" ID) UCKT5 tubing. Adjust flow rates for these products to approximately 300 ml/min (30 psig on the PG-05 gauge). Then follow the manufacturer's installation instructions to complete calibration.

## KELE OS-1 OXYGEN SENSOR

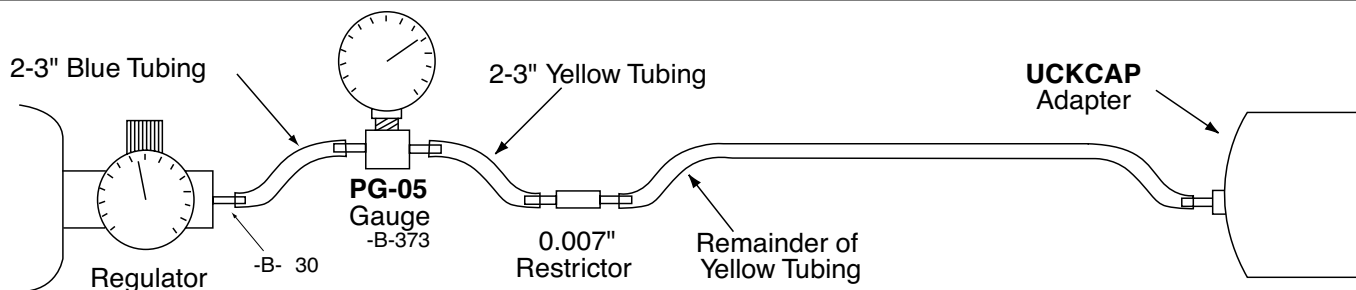

The OS-1 oxygen sensor is designed to be calibrated in ambient air (20.95% Oxygen), and thus no calibration gas is generally needed; however, to check calibration or prove operation, the UCK may be connected. Use a short (2-3") length of blue (3/16" ID) UCKT5 tubing from the 51-226AB6610 regulator and X-B-130 to the X-B-373 fitting and attach the PG-05 gauge, then a short (2-3") length of yellow (5/32" ID) UCKT4 tubing to the 0.007" R-3710-2007 restrictor. Connect the remainder of the yellow (5/32" ID) tubing from the restrictor to X-B-130 fitting, and then one can drill a hole in the all-purpose cap adapter (UCKCAP) and attach the fitting. The OS-1 sensing element is located in the 1" fitting that protrudes from the bottom of the unit. Mate the UCKCAP to the OS-1 fitting and hold or secure with tape on two sides only. Do not completely seal the gap between the fittings since it is needed to vent the spent gas. Adjust flow rates for these products to approximately 500 ml/min (10 psig on the PG-05 gauge). Then follow the manufacturer's installation instructions to complete calibration.

## KELE RLD-5 AND RLD-134a REFRIGERANT LEAK DETECTORS

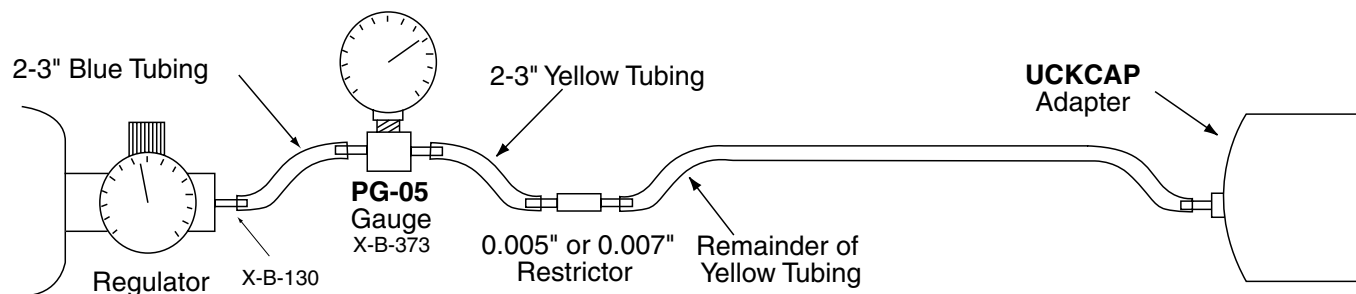

Calibration of these sensors does not require the use of calibration gas; however, to check calibration or prove operation, the UCK may be connected. Use a short (2-3") length of blue (3/16" ID) UCKT5 tubing from the 51-226AB6610 regulator and X-B-130 to the X-B-373 fitting and attach the PG-05 gauge, then a short (2-3") length of yellow (5/32" ID) UCKT4 tubing to the 0.005/7" R-3710-2005/7 restrictor. Connect the remainder of the yellow (5/32" ID) tubing from the restrictor to X-B-130 fitting, and then one can drill a hole in the all-purpose cap adapter (UCKCAP) and attach the fitting. The RLD-5 and RLD-134a sensing element is located on the front of the unit. Simply cover the sensor with the UCKCAP all-purpose adapter and hold it flush with the cover, or secure it with tape on two sides only. Do not completely seal the gap between the UCKCAP and the cover since it is needed to vent the spent gas. Adjust flow rates for these products to approximately 200 ml/min (14 psig on the PG-05 gauge). Then follow the manufacturer's installation instructions to complete calibration.

**KELE WCO-1B AND WCO-1D CARBON MONOXIDE SENSORS**

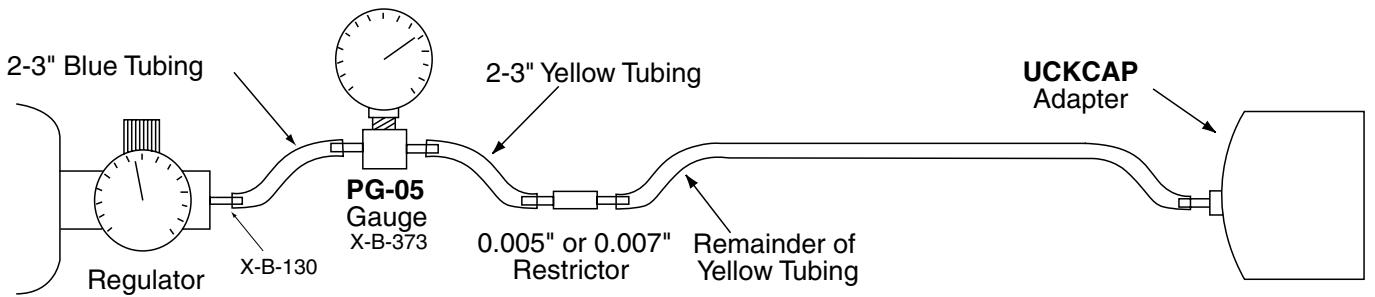

Use a short (2-3") length of blue (3/16" ID) UCKT5 tubing from the 51-226AB6610 regulator and X-B-130 to the X-B-373 fitting and attach the PG-05 gauge, then a short (2-3") length of yellow (5/32" ID) UCKT4 tubing to the 0.005/7" R-3710-2005/7 restrictor. Connect the remainder of the yellow (5/32" ID) tubing from the restrictor to X-B-130 fitting, and then one can drill a hole in the all-purpose cap adapter (UCK-CAP) and attach the fitting. Open the WCO product to expose the sensing element (a cylindrical device labeled "Figaro TGS" on top). Simply place the UCKCAP over the sensor loosely and adjust the flow rate to approximately 80 ml/min for these products (2 psig on the PG-05 gauge). Then follow the manufacturer's installation instructions to complete calibration.

**SPC3-1000/3000 SERIES TOXIC / COMBUSTIBLE GAS SENSORS**

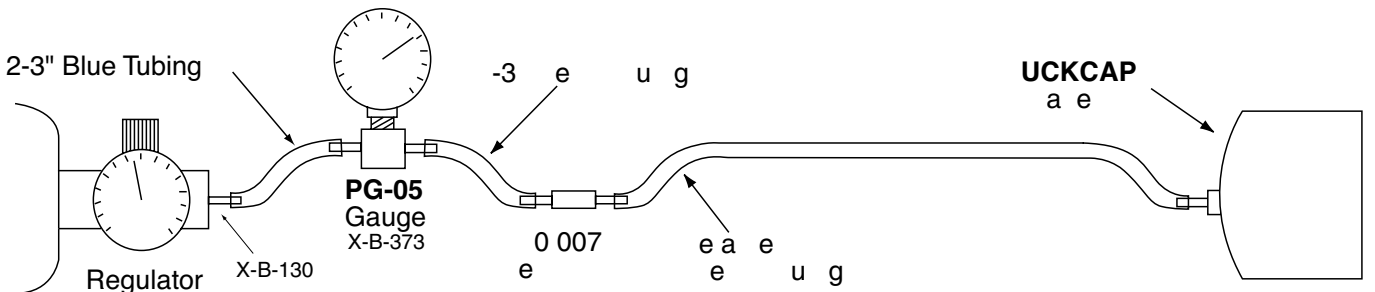

Use a short (2-3") length of blue (3/16" ID) UCKT5 tubing from the regulator (Either 51-226AB6610 and X-B-130 or UCKR58) to the X-B-373 fitting and attach the PG-05 gauge, then a short (2-3") length of yellow (5/32" ID) UCKT4 tubing to the 0.007" R-3710-2007 restrictor. Connect the remainder of the yellow (5/32" ID) tubing from the restrictor to X-B-130 fitting, and then one can drill a hole in the all-purpose cap adapter (UCKCAP) and attach the fitting. If the sensor is in very tight quarters or the area is breezy, a length of duct tape may be formed into a skirt around the UCKCAP to concentrate the gas flow around the sensor. Do not completely seal the UCKCAP to the sensor since a gap is needed to vent the spent gas. Adjust flow rates for these products to the recommended values for the gas in question, as shown below. For gases not shown, contact a Kele Technical Sales Representative for additional information. Then follow the manufacturer's installation instructions to complete calibration.

**FLOW RATE TABLE 4**

GAS	FLOW RATE (ml/min)	RESTRICTOR/UPSTREAM PRESSURE
Carbon monoxide (CO)	150	0.007" - 1 psig
Nitrogen dioxide (NO2)	150	0.007" - 1 psig
Hydrogen (H2)	300	0.007" - 4 psig
Combustibles	300	0.007" - 4 psig
Oxygen (O2)	150	0.007" - 1 psig
Ammonia (NH3)	150	0.007" - 1 psig

**DWYER CDT SERIES CO2 SENSORS**

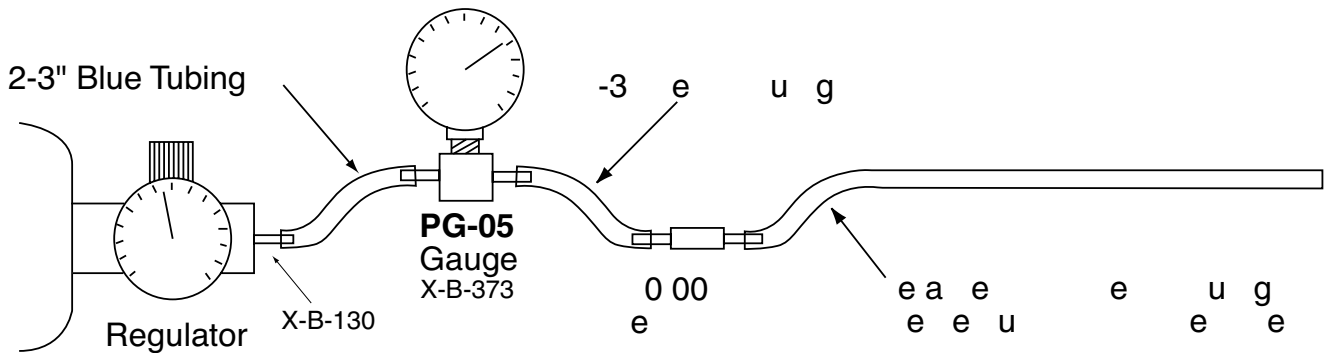

The Dwyer CDT series Connect to the sensor with the red (1/8" ID) UCKT3 tubing. Use a X-B-261 reducing fitting to connect the red tubing to a short (2-3") length of yellow (5/32" ID) UCKT4 tubing, then to the 0.005" R-3710-2005 restrictor. Use a second short (2-3") length of yellow (5/32" ID) tubing from the restrictor to the X-B-373 fitting and attach the PG-05 gauge. From the gauge to the 51-226AB6610 regulator and X-B-130 use a short (2-3") length of blue (3/16" ID) UCKT5 tubing. Adjust flow rates for these products to approximately 300 ml/min (about 4 psig on the PG-05 gauge). Then follow the manufacturer's installation instructions to complete calibration.

**KELE KCD/W, KCO2, KCOC, KCOP AND KTS SERIES**

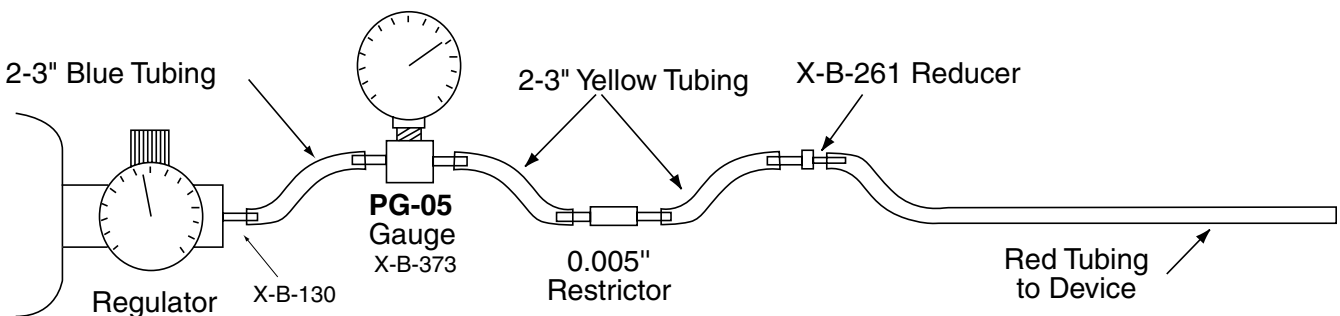

Connect to the sensor with the red (1/8" ID) UCKT3 tubing. Use a X-B-261 reducing fitting to connect the red tubing to a short (2-3") length of yellow (5/32" ID) UCKT4 tubing, then to the 0.005" R-3710-2005 restrictor. Use a second short (2-3") length of yellow (5/32" ID) tubing from the restrictor to the X-B-373 fitting and attach the PG-05 gauge. From the gauge to the 51-226AB6610 regulator and X-B-130 use a short (2-3") length of blue (3/16" ID) UCKT5 tubing. Adjust flow rates for these products to approximately 50 ml/min (about 1 psig on the PG-05 gauge). Then follow the manufacturer's installation instructions to complete calibration.



### GMD/W SENSOR

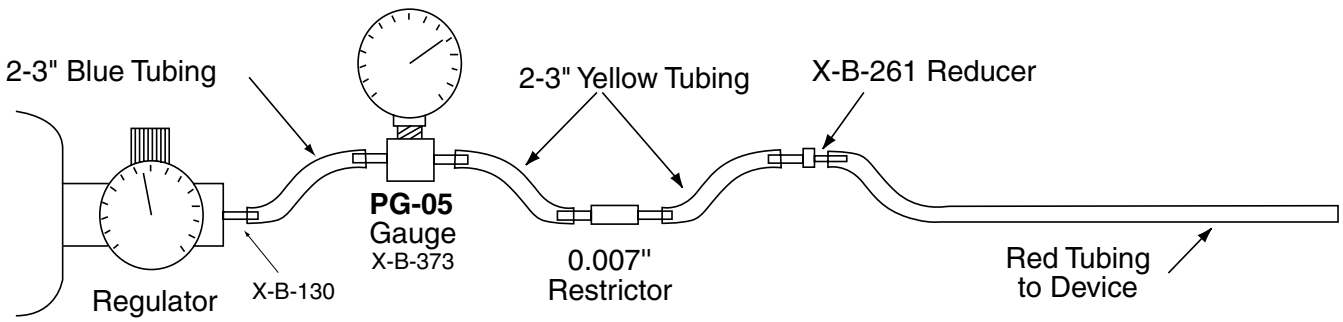

With the sensor open, remove the cap from the calibration gas connection on the side of the optical chamber. Connect to the sensor with the red (1/8" ID) UCKT3 tubing. Use a X-B-261 reducing fitting to connect to a short (2-3") length of yellow (5/32" ID) UCKT4 tubing, then to the 0.007" R-3710-2007 restrictor. Use another short (2-3") length of yellow (5/32" ID) tubing from the restrictor to the X-B-373 fitting and attach the PG-05 gauge. From the gauge to the 51-226AB6610 regulator and X-B-130 use a short (2-3") length of blue (3/16" ID) UCKT5 tubing. Adjust flow rates for these products to approximately 600 ml/min (about 15 psig on the PG-05 gauge). Then follow the manufacturer's installation instructions to complete calibration.

### IR-F9 SENSORS

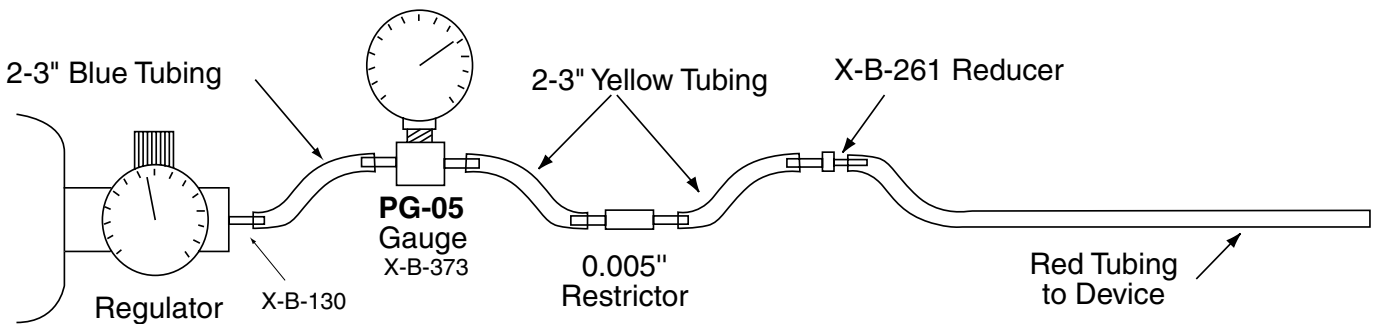

The device has a draw chamber with a barbed connector which is the red (1/8" ID) UCKT3 tubing. Use the X-B-261 reducing coupling to connect with short (2-3") length of yellow (5/32" ID) UCKT4 tubing to the 0.005" R-3710-2005 restrictor. Connect the restrictor to the X-B-373 fitting and attach the PG-05 gauge with a second short (2-3") length of yellow (5/32" ID) tubing. From the gauge to the 51-226AB6610 regulator and X-B-130 use a short (2-3") length of blue (3/16" ID) UCKT5 tubing. Adjust flow rates for these products to approximately 100 ml/min (4 psig on the PG-05 gauge). Then follow the manufacturer's installation instructions to complete calibration.

### KELE GDS/GDD/GDN SERIES TOXIC / COMBUSTIBLE GAS SENSORS

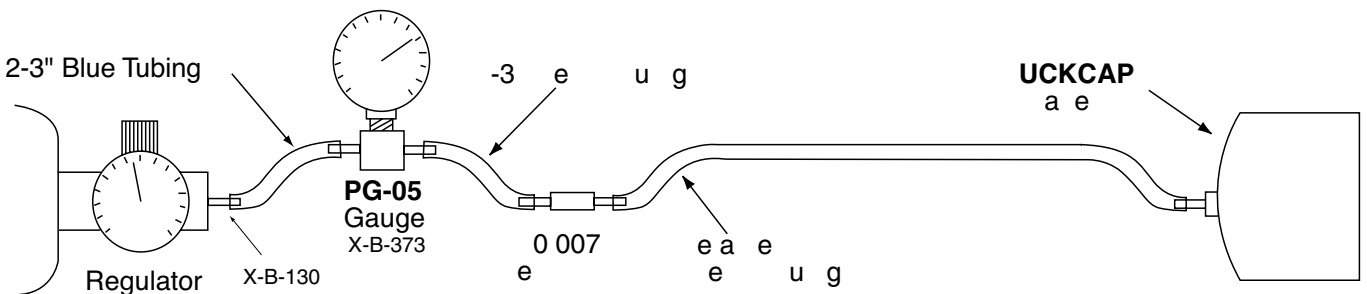

Use a short (2-3") length of blue (3/16" ID) UCKT5 tubing from the regulator (Either 51-226AB6610 or UCKR58) to the X-B-373 fitting and attach the PG-05 gauge, then a short (2-3") length of yellow (5/32" ID) UCKT4 tubing to the 0.007" R-3710-2007 restrictor. Connect the remainder of the yellow (5/32" ID) tubing from the restrictor to X-B-130 fitting, and then one can drill a hole in the all-purpose cap adapter (UCKCAP) and attach the fitting. Plug the adapter into the mating recess on the front cover of the GDS/GDD/GDN, or at the sensor end in an explosion proof SPX. Adjust flow rates for these products to the recommended values for the gas in question, as shown below. For gases not shown, contact a Kele Technical Sales Representative for additional information. Then follow the manufacturer's installation instructions to complete calibration.

**TABLE 5 FLOW RATE**

<b>GAS</b>	<b>FLOW RATE (ml/min)</b>	<b>RESTRICTOR/UPSTREAM PRESSURE</b>
<b>Carbon monoxide (CO)</b>	500	0.007" - 10 psig
<b>Nitrogen dioxide (NO2)</b>	500	0.007" - 10 psig
<b>Hydrogen (H2)</b>	500	0.007" - 10 psig
<b>Combustibles</b>	500	0.007" - 10 psig
<b>Hydrogen sulfide (H2S)</b>	1000	(no restrictor)
<b>Oxygen (O2) - S1</b>	80	0.005" - 2 psig

**IAQ-A/N SERIES SENSORS**

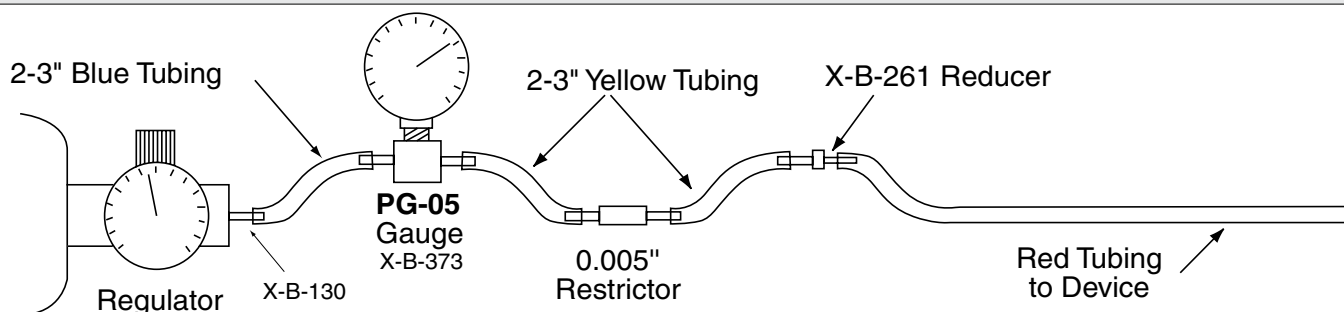

On the side of the device is a port to connect the red (1/8" ID) UCKT3 tubing to the barbed connector. Use the X-B-261 reducing coupling to connect with short (2-3") length of yellow (5/32" ID) UCKT4 tubing to the 0.005" R-3710-2005 restrictor. Connect the restrictor to the X-B-373 fitting and attach the PG-05 gauge with a second short (2-3") length of yellow (5/32" ID) tubing. From the gauge to the 51-226AB6610 regulator and X-B-130, use a short (2-3") length of blue (3/16" ID) UCKT5 tubing. Adjust flow rates for these products to approximately 100 ml/min (4 psig on the PG-05 gauge). Then follow the manufacturer's installation instructions to complete calibration.

**KELE KCO CARBON MONOXIDE SENSOR (PRIOR TO 8/1/2016)**

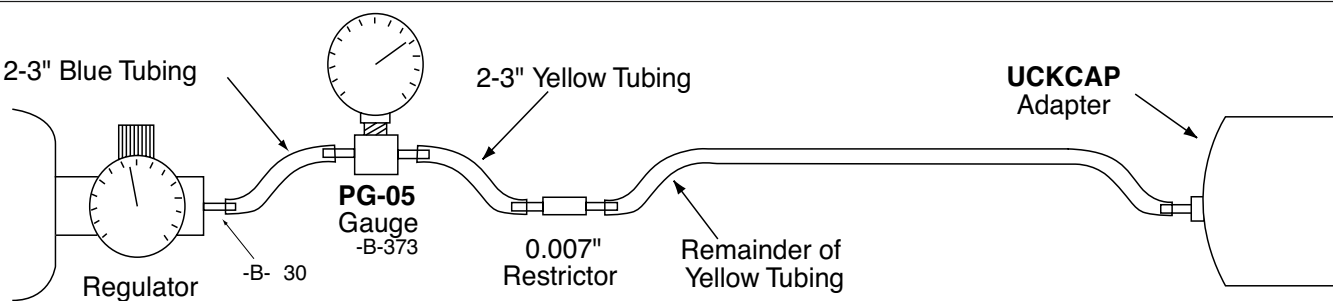

Use a short (2-3") length of blue (3/16" ID) UCKT5 tubing from the 51-226AB6610 regulator and X-B-130 to the X-B-373 fitting and attach the PG-05 gauge, then a short (2-3") length of yellow (5/32" ID) UCKT4 tubing to the 0.007" R-3710-2007 restrictor. Connect the remainder of the yellow (5/32" ID) tubing from the restrictor to X-B-130 fitting, and then one can drill a hole in the all-purpose cap adapter (UCKCAP) and attach the fitting. If the sensor is in very tight quarters or the area is breezy, a length of duct tape may be formed into a skirt around the UCKCAP to concentrate the gas flow around the sensor. Do not completely seal the UCKCAP to the sensor since a gap is needed to vent the spent gas. Adjust the flow rate to approximately 700 ml/min for these products (20 psig on the PG-05 gauge). Then follow the manufacturer's installation instructions to complete calibration.

## KELE KCO CARBON MONOXIDE SENSOR (AFTER TO 8/1/2016)

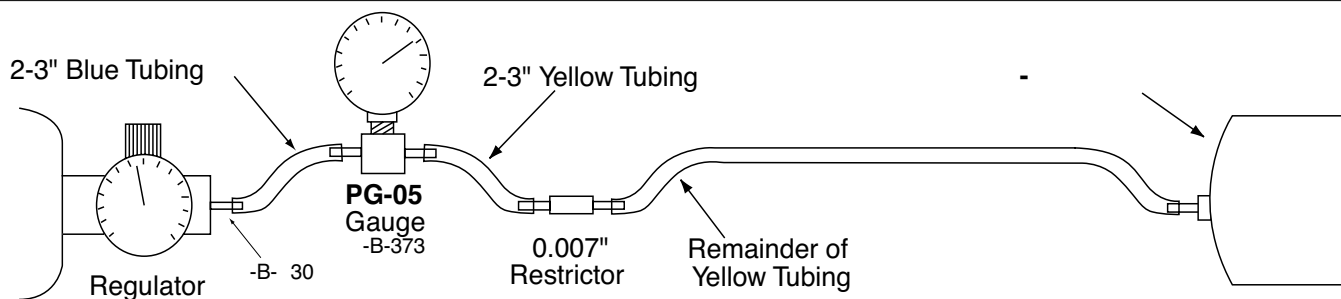

Use a short (2-3") length of blue (3/16" ID) UCKT5 tubing from the 51-226AB6610 regulator and X-B-130 to the X-B-373 fitting and attach the PG-05 gauge, then a short (2-3") length of yellow (5/32" ID) UCKT4 tubing to the 0.007" R-3710-2007 restrictor. Connect the remainder of the yellow (5/32" ID) tubing from the restrictor to X-B-130 fitting, and attach CMD-Calhose Kit. Adjust the flow rate to approximately 700 ml/min for these products (20 psig on the PG-05 gauge). Then follow the manufacturer's installation instructions to complete calibration.

## VA301RFS SERIES SENSORS

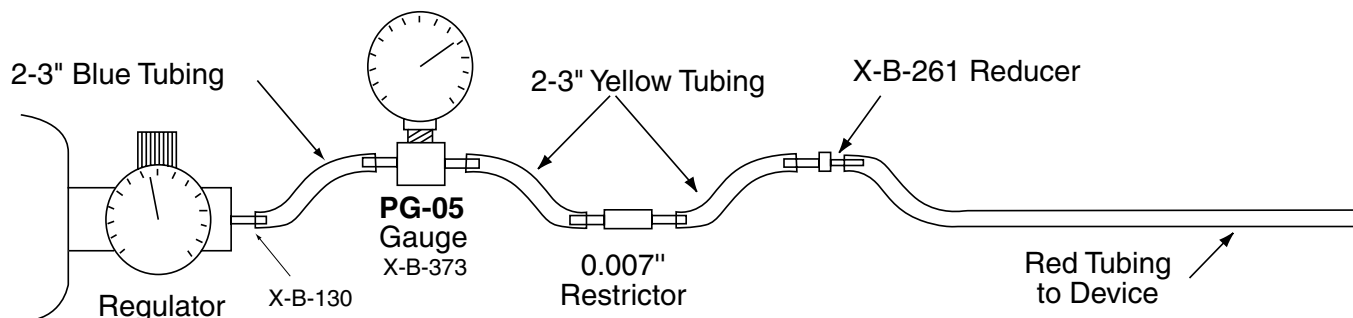

On the side of the device is a port to connect the red (1/8" ID) UCKT3 tubing to the barbed connector. Use the X-B-261 reducing coupling to connect with short (2-3") length of yellow (5/32" ID) UCKT4 tubing to the 0.007" R-3710-2007 restrictor. Connect the restrictor to the X-B-373 fitting and attach the PG-05 gauge with a second short (2-3") length of yellow (5/32" ID) tubing. From the gauge to the 51-226AB6610 regulator and X-B-130 use a short (2-3") length of blue (3/16" ID) UCKT5 tubing. Adjust flow rates for these products to approximately 500 ml/min (10 psig on the PG-05 gauge). Then follow the manufacturer's installation instructions to complete calibration.

### S301 SENSORS

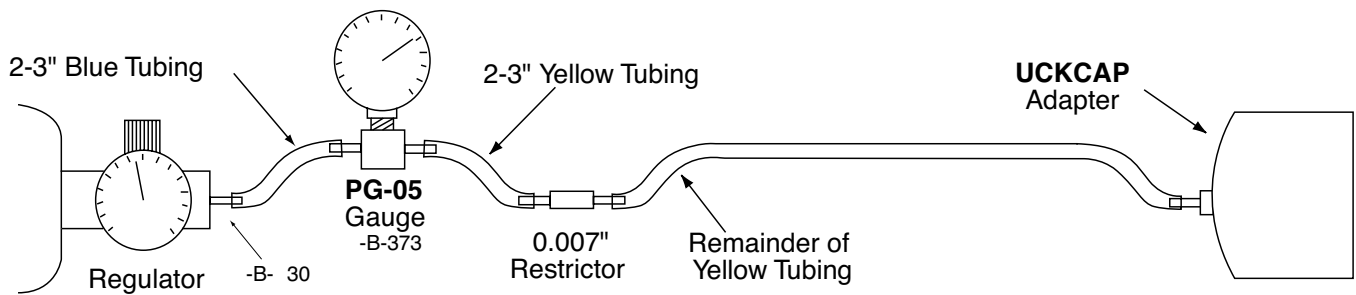

Use a short (2-3") length of blue (3/16" ID) UCKT5 tubing from the regulator (Either 51-226AB6610 and X-B-130 or UCKR58) to the X-B-373 fitting and attach the PG-05 gauge, then a short (2-3") length of yellow (5/32" ID) UCKT4 tubing to the 0.007" R-3710-2007 restrictor. Connect the remainder of the yellow (5/32" ID) tubing from the restrictor to X-B-130 fitting, and then one can drill a hole in the all-purpose cap adapter (UCKCAP) and attach the fitting. Simply place the UCKCAP over the sensor loosely and adjust the flow rate to the manufacturer's recommended level (see below for restrictor and pressure choice). If the sensor is in very tight quarters or the area is breezy, a length of duct tape may be formed into a skirt around the UCKCAP to concentrate the gas flow around the sensor. Do not completely seal the UCKCAP to the sensor since a gap is needed to vent the spent gas. Then follow the manufacturer's installation instructions to complete calibration.

**TABLE 6 FLOW RATE**

<b>GAS</b>	<b>FLOW RATE (ml/min)</b>	<b>RESTRICTOR/UPSTREAM PRESSURE</b>
<b>Carbon monoxide (CO)</b>	500	0.007" - 10 psig
<b>Nitrogen dioxide (NO2)</b>	500	0.007" - 10 psig

### GDC-150/350 SERIES TOXIC/COMBUSTIBLE GAS SENSORS

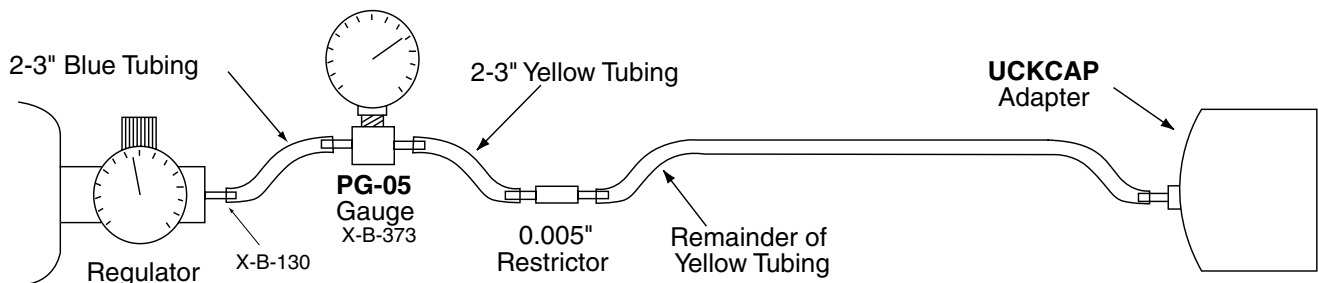

Use a short (2-3") length of blue (3/16" ID) UCKT5 tubing from the regulator (Either 51-226AB6610 and X-B-130 or UCKR58) to the X-B-373 fitting and attach the PG-05 gauge, then a short (2-3") length of yellow (5/32" ID) UCKT4 tubing to the 0.007" R-3710-2007 restrictor. Connect the remainder of the yellow (5/32" ID) tubing from the restrictor to X-B-130 fitting, and then one can drill a hole in the all-purpose cap adapter (UCKCAP) and attach the fitting. Cover on the front cover of the GDC-150/350. Adjust flow rates for these products to the recommended values for the gas in question, as shown below. For gases not shown, contact a Kele Technical Sales Representative for additional information. Then follow the manufacturer's installation instructions to complete calibration.

**TABLE 7 FLOW RATE**

<b>GAS</b>	<b>FLOW RATE (ml/min)</b>	<b>RESTRICTOR/UPSTREAM PRESSURE</b>
<b>Carbon monoxide (CO)</b>	500	0.007" - 10 psig
<b>Nitrogen dioxide (NO2)</b>	500	0.007" - 10 psig
<b>Hydrogen (H2)</b>	500	0.007" - 10 psig
<b>Combustibles</b>	500	0.007" - 10 psig
<b>Refridgerants</b>	500	0.007" - 10 psig
<b>Oxygen (O2) - S1</b>	500	0.007" - 10 psig
<b>Nitrogen oxide (NO)</b>	500	0.007" - 10 psig
<b>Sulfur dioxide (SO2)</b>	500	0.007" - 10 psig

**TABLE 8 FLOW RATE**

<b>GAS</b>	<b>FLOW RATE (ml/min)</b>	<b>RESTRICTOR/UPSTREAM PRESSURE</b>
<b>Nitrogen dioxide (NO2)</b>	500	0.007" - 10 psig
<b>Sulfur dioxide (SO2)</b>	500	0.007" - 10 psig

**AGM-SZ SERIES SENSORS**

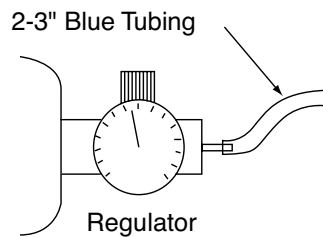

Get plastic bag and put AGM-SZ sampling tube inside. Use GAS-NH3-1000 and UCKR58 regulator along with UCKT5 tubing. Then flow gas from regulator and tubing into plastic bag. The bag just needs to remain filled during calibration and because the AGM-SZ samples such a small volume; bag must be hand regulated. Then follow the manufacturer’s installation instructions to complete calibration.

## HGM-SZ/MZ SERIES SENSORS

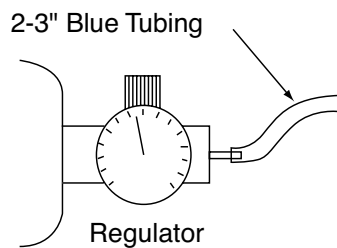

Get plastic bag and put HGM-SZ/MZ sampling tube inside. Use Refrigerant GAS-XX-XXX and 51-226AB6610 regulator along with UCKT5 tubing. Then flow gas from regulator and tubing into plastic bag. The bag just needs to remain filled during calibration and because the HGM-SZ/MZ samples such a small volume; bag must be hand regulated. Then follow the manufacturer's installation instructions to complete calibration.

## VASQN8 SERIES SENSORS

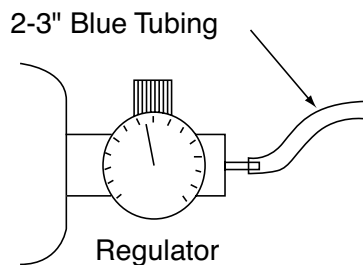

Use Refrigerant GAS-XX-XXX and 51-226AB6610 regulator along with UCKT3 7 5 tubing. Then flow gas from regulator and tubing into the VASQN8 sensor directly. Then follow the manufacturer's installation instructions to complete calibration.