



GAS & SPECIALTY SENSORS

DUCT SMOKE DETECTORS SM-501 SERIES

DESCRIPTION

The **Air Products & Controls SM-501 Series Duct Smoke Detectors** provide early detection of smoke and combustion products present in air moving through HVAC ducts. Air sampling is accomplished by intake sampling tubes, which are ordered separately. A standard length exhaust tube is provided with each detector. The **SM-501 Series** is designed to operate in duct widths from 6" (15 cm) to 10.0' (3.05m) with an air velocity from 500-4000 fpm (2.5-20.3 mps). Complete systems may be shut down in the event of smoke detection.



SM-501



OPERATION

The **SM-501 Series** will operate on any one of four input voltages: 24 VAC, 24 VDC, 115 VAC, or 230 VAC. It uses either photoelectric or ionization smoke detector heads. Each detector contains two alarm contacts, which transfer in the event of smoke, and one trouble contact, which supervises the presence of input power and removal of the detector head. A manual test/reset switch and visual indicators of pilot and alarm are provided on the front of the detector. Up to 30 **SM-501 Series** units may be wired to use a common test/reset function and to alarm simultaneously when a single unit alarms. If remote signal devices such as horns or strobes are used, up to 15 detectors may be interconnected to operate with a single alarm.

FEATURES

- **Universal voltage: 24 VAC, 24 VDC, 115 VAC, or 230 VAC**
- **Remote reset, alarm, and indication available**
- **Two alarm contacts and one trouble contact**
- **Interchangeable "plug-in" photoelectric or ionization heads**
- **Compatible with building automation and fire alarm systems**
- **Dust filtering included in detector head**
- **Interconnect up to 30 detectors for common functions**

SPECIFICATIONS

Supply Voltage	(without accessories) 24 VAC @ 35 mA standby, 74 mA alarm 24 VDC @ 15 mA standby, 56 mA alarm 115 VAC @ 25 mA standby, 32 mA alarm 230 VAC @ 12 mA standby, 16 mA alarm	Wiring Terminations	Solid or stranded, 12 to 22 AWG terminals
Frequency	50/60 Hz	Operating Temperature	
Relay Contacts	Alarm 2-SPDT, 10A, 115 VAC, resistive Trouble 1-SPDT, 10A, 115 VAC, resistive	SM-501-N	32° to 158°F (0° to 70°C)
Air Velocity	500-4000 fpm (2.5-20.3 mps)	SM-501-P	32° to 140°F (0° to 60°C)
Radioactive Element	For SM-501-N only Americium 241, 0.9 µCi	Operating Humidity	10% to 85% RH non-condensing
		Enclosure Rating	NEMA 1, 18-gauge steel back box, clear plastic cover (94V-0), Gray paint with clear cover
		Dimensions	9.13"H x 7.25"W x 2.25"D (23.19 x 18.42 x 5.72 cm)
		Weight	3.2 lb (1.45 Kg)
		Approvals	UL File #S2829 CSFM 3240-1004:108 MEA 73-92-E, Vol. 26
		Warranty	3 year



DUCT SMOKE DETECTORS SM-501 SERIES

MOUNTING

Mount the detector in an air duct using the provided template and four sheet metal screws. Detector must be mounted at least six duct widths from the fan or other sources of turbulence with airflow from 500-4000 fpm (2.5-20.3 mps). The intake sampling tube has holes drilled the entire length of the tube and should extend the entire width of the duct. The holes must be facing into the airflow (see Figure 1 to the right). The exhaust tube is a piece of steel piping approximately 7" long (17.8 cm).

Intake Sampling Tube Lengths

Model	Duct Width
STS-2.5	6.0" to 2.5' (0.15 to 0.7m)
STS-5.0	2.5' to 5.0' (0.7 to 1.5m)
STS-10.0	5.0' to 10.0' (1.5 to 3m)

Installation

1. Cut the intake sampling tube to the desired length.
2. Firmly insert the stopper (provided with the detector) in the end of the intake sampling tube.
3. Follow instruction sheet provided with each detector.

FIGURE 1. TYPICAL DUCT INSTALLATION

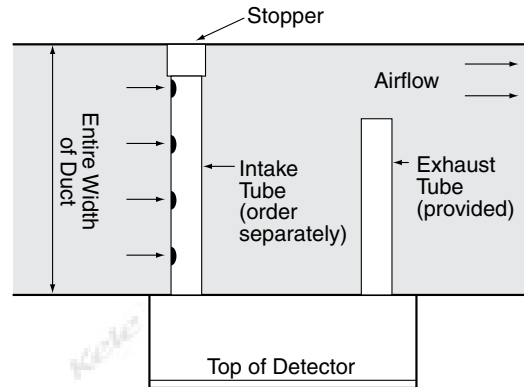

Note: Sampling tubes over 3' (0.9m) must be supported on the opposite side of the duct from the detector.

WIRING

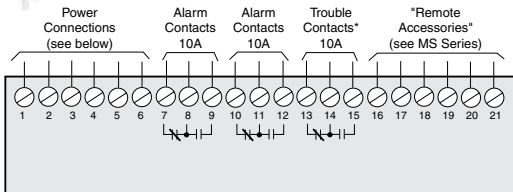

CAUTION: For terminals 7, 8, 9, 10, 11, and 12, do not use looped wire under terminals. Break wire run to provide supervision of connections.

*Trouble contacts are shown in non-energized condition. Under normal operation contacts will be reversed.

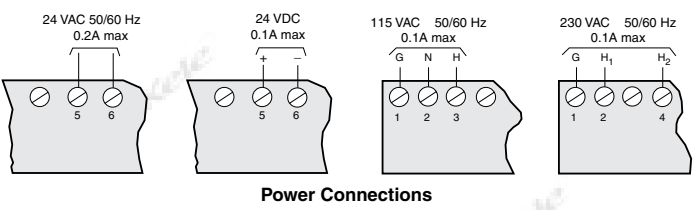

Power Connections

INTERCONNECTING WIRING

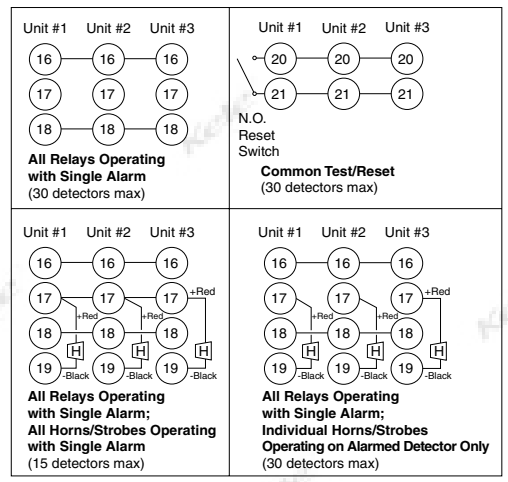

Note: Use a common independent power supply for all interconnected detectors.

ORDERING INFORMATION

MODEL	DESCRIPTION
SM-501-N	Ionization duct smoke detector for 24 VAC, 24 VDC, 115 VAC, 230 VAC
SM-501-P	Photoelectric duct smoke detector for 24 VAC, 24 VDC, 115 VAC, 230 VAC

	RELATED PRODUCTS
55000-225APO	Replacement ionization smoke detector head only
55000-328APO	Replacement photoelectric smoke detector head only
STS-10.0	Sampling tube for 5.0' to 10.0' (1.5 to 3m) duct widths
STS-2.5	Sampling tube for 6.0" to 2.5' (0.15 to 0.7m) duct widths
STS-5.0	Sampling tube for 2.5' to 5.0' (0.7 to 1.5m) duct widths
TG-1000	Aerosol test gas
WP-1	NEMA 3R enclosure for SM Series duct smoke detector

	ACCESSORIES
691-K0A	Control transformer, 120:24 VAC, 40 VA, Class 2
DCP-1.5-W	Power supply, 24 VAC IN to 24 VDC OUT
DCPA-1.2	Power supply, 120 VAC IN to 24 VAC/24 VDC OUT

7 GAS & SPECIALTY SENSORS