

## M9206-Bxx-2S Series On/Off Electric Spring Return Actuators

### Installation

**IMPORTANT:** Use this M9206-Bxx-2S Series actuator to control equipment under normal operating conditions. Where failure or malfunction of the M9206-Bxx-2S Series actuator could lead to personal injury or property damage to the controlled equipment or other property, additional precautions must be designed into the system. Incorporate and maintain other devices such as supervisory or alarm systems or safety or limit controls intended to warn of, or protect against, failure or malfunction of the M9206-Bxx-2S Series actuator.

### Parts Included

- M9206-Bxx-2S actuator
- M9000-161 anti-rotation bracket
- two No. 12-24 sheet metal screws

### Special Tools Required

- 5/16 in. (8 mm) nut driver
- 5/16 in. (8 mm) square socket or 3/8 in. (10 mm) 12-point socket
- drill with a 3/16 in. (No. 15, 4.57 mm) drill bit

### Setup and Adjustments

#### Spring Return Direction - Counterclockwise (CCW) Operation

For CCW spring return operation, mount the actuator to the damper shaft so the CCW face of the actuator (Figure 1) is away from the damper. The coupler is at the 0° position to drive Clockwise (CW) and spring return CCW.

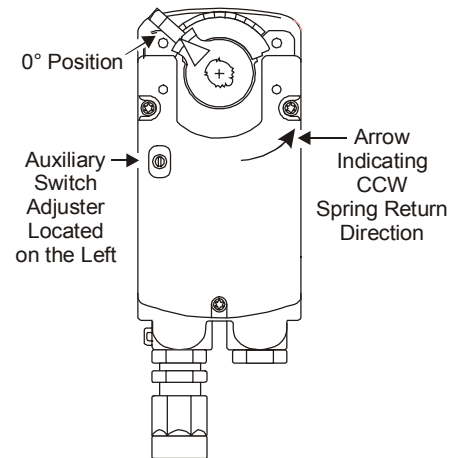

**Figure 1: CCW Face of the Actuator**

#### Spring Return Direction - CW Operation

To change the spring return direction to CW, mount the actuator to the damper shaft so the CW face of the actuator (Figure 2) is away from the damper. The actuator now drives CCW from the 0° position.

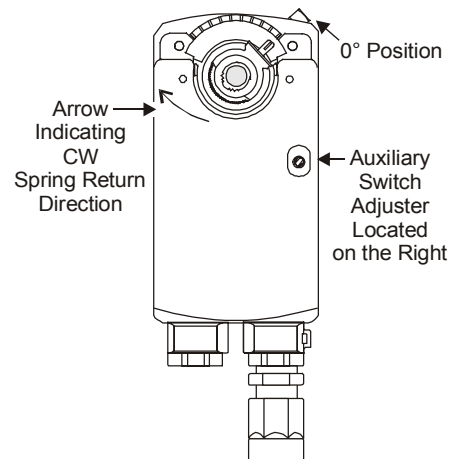

**Figure 2: CW Face of the Actuator**

The coupler can be inserted in the CW face of the actuator for easier access to the coupler set screw. (Refer to the *Removable Coupler* section.)

## Removable Coupler

If the damper shaft is less than 3.2 in. (80 mm) long, the coupler must be inserted in the face of the actuator closest to the damper.

If the damper shaft is shorter than 1.7 in. (42 mm), a shaft extension is required to mount the actuator.

To change the coupler's position, refer to Figure 3 and proceed as follows:

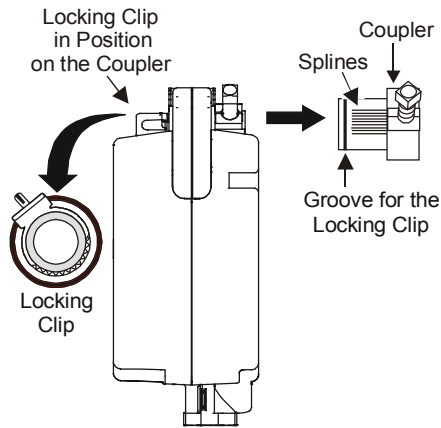

**Figure 3: Changing the Position of the Coupler**

1. Pull the locking clip off the coupler, and remove the coupler from the actuator.

**Note:** For setting a rotation range of less than 90°, proceed to the *Rotation Range* section.

For 0 to 93° rotation, the coupler must fit as closely as possible to, but not on top of, the metal plate at the spring return position.

2. Reinsert the coupler into either the CW or CCW face of the actuator (determined by the shaft length discussed earlier in this section).

**Note:** The coupler splines (Figure 3) are designed to prevent insertion of the coupler at the wrong end of the rotation range.

3. Snap the locking clip securely into the coupler groove to retain the coupler in the actuator.

## Mounting

### Location Considerations

Mount the M9206-Bxx-2S actuators in any convenient orientation. Install the actuators on a 3/8 to 1/2 in. (10 to 13 mm) round shaft and a 3/8 in. (9.5 mm) square shaft. If the shaft extends less than 3.2 in. (80 mm), refer to the *Removable Coupler* section.

**IMPORTANT:** Do not install this actuator in condensing, wet or damp environments. Moisture may cause damage to the actuator.

## Actuator Mounting

To mount the actuator, proceed as follows:

1. Bend or cut the anti-rotation mounting bracket to fit the damper frame or duct as shown in Figure 4. (The bracket can be bent to fit a round damper.)

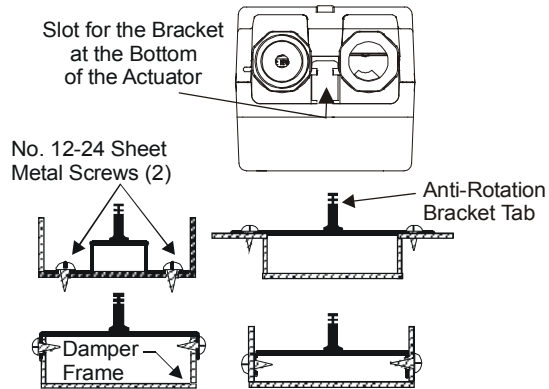

**Figure 4: Anti-Rotation Mounting Bracket Positions**

2. Slide the actuator onto the damper shaft.

**CAUTION: Risk of Property Damage.** Mount the actuator perpendicular to the shaft. Failure to mount the actuator perpendicular to the shaft may cause the shaft to bind. Binding may result in damage to the actuator or other property, and will void the warranty.

3. Position the anti-rotation mounting bracket into the slot at the bottom of the actuator. Use the most appropriate pair of notches in the bracket tab (Figure 4).

**IMPORTANT:** Place the anti-rotation bracket tab midway in the actuator slot. Failure to do so may cause the actuator to bind, may cause premature wear, and will void the warranty.

- Refer to the A through D dimensions in Figure 5 and Table 1 to ensure the anti-rotation mounting bracket tab fits midway in the actuator slot.

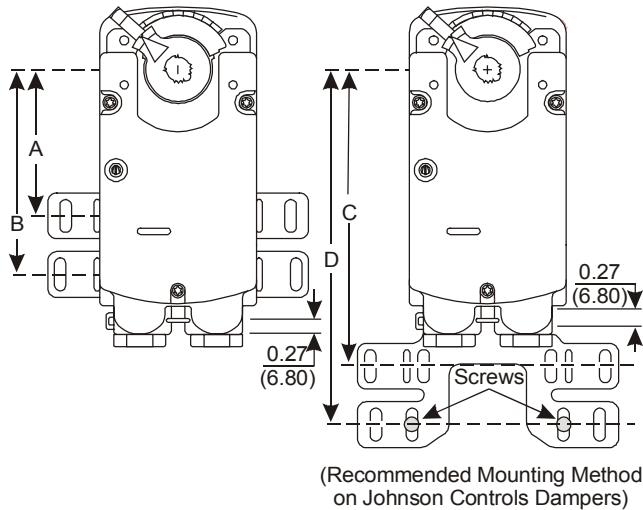

**Figure 5: Mounting Positions, in. (mm)**

**Table 1: Shaft Sizes and Distances from the Anti-Rotation Bracket to Shaft Center**

Dimensions in. (mm)	Shaft Diameter	
	1/2 in. (mm)	3/8 in. (mm)
<b>A</b>	3.00 (76.3)	2.94 (74.7)
<b>B</b>	4.23 (107.5)	4.17 (105.9)
<b>C</b>	6.11 (155.3)	6.05 (153.7)
<b>D</b>	7.35 (186.6)	7.30 (185.0)

- Use the anti-rotation mounting bracket as a guide, and drill the holes in the damper frame or duct for the bracket (based on the measurements obtained in Figure 5 and Table 1).

**Note:** When installing the actuator to a Johnson Controls® D-1300 damper, use the existing holes in the damper frame.

- Rotate the damper to the position desired when power is lost. If a tight seal is required, rotate the actuator 3° away from the spring return direction.
- Tighten the coupler set screw onto the damper shaft. Recommended torque for the set screw is 150 to 180 lb·in (17 to 20 N·m).
- Attach the anti-rotation mounting bracket to the damper frame or duct with the two sheet metal screws provided, using a 5/16 in. (8 mm) nut driver.

**Note:** Do not overtighten the mounting screws. Overtightening may strip the threads.

- Verify that the actuator rotates freely throughout the range by applying power long enough for the actuator to travel a full stroke.

### Rotation Range

The actuator is factory set for 0 to 93° rotation.

**Note:** The minimum rotation range is 34.5°.

To reduce the rotation range, reposition the coupler as follows:

- Make sure that the damper blade is visible or its position is permanently marked on the end of the damper shaft as shown in Figure 6.

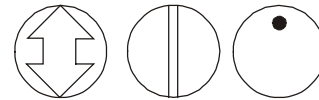
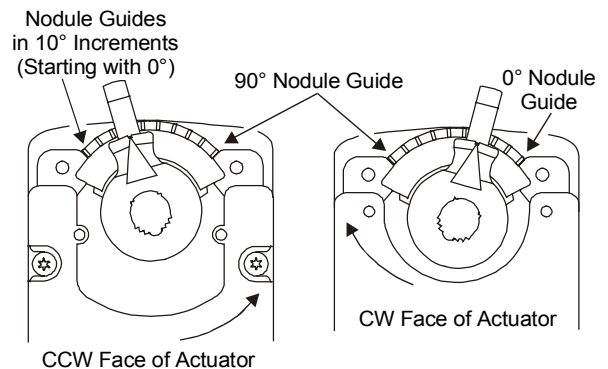

**Figure 6: Damper Position Icons**

- Determine the desired rotation range, and subtract this number from 90°.
- Remove the locking clip from the coupler. (See Figure 3.)
- Manually reposition the coupler, so the coupler set screw aligns with the nodule guide that corresponds to the value determined in Step 2.

Examples:

- For a rotation range of 60°, move the coupler so the coupler set screw is at the 30° nodule guide (90° – 60° = 30°). Refer to Figure 7.

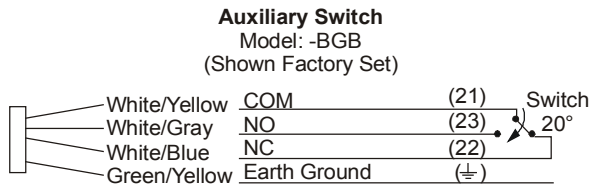
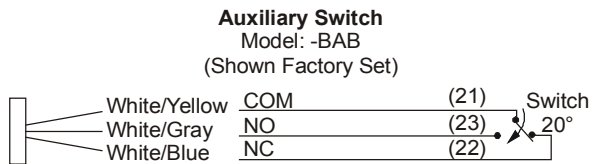
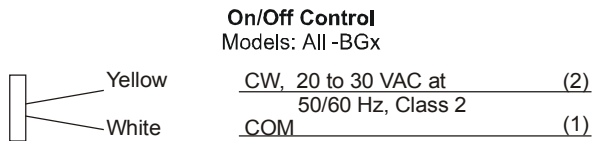
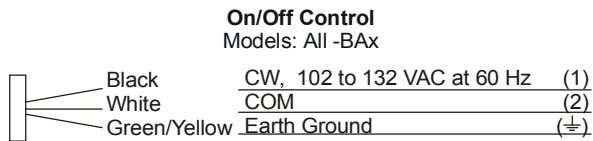

**Figure 7: Actuator Set for 60° Rotation**

- For a rotation range of 45°, move the coupler so the coupler set screw is midway between the 40° and 50° nodule guides (90° - 45° = 45°).
- Snap the locking clip securely into the coupler groove to retain the coupler in the actuator.

## Wiring

Refer to Figure 8 to wire the applicable M9206-Bxx-2S model.



**Figure 8: Wiring Diagrams for M9206-Bxx-2S Models**



### **WARNING: Risk of Electrical Shock.**

Disconnect each of multiple power supplies before making electrical connections. More than one disconnect may be required to completely de-energize equipment. Contact with components carrying hazardous voltage can cause electrical shock and may result in severe personal injury or death.



**WARNING: Risk of Electrical Shock and Property Damage.** Insulate and secure each unused wire lead before applying power to the actuator. Failure to insulate and secure each unused wire lead may result in property damage, electrical shock, and severe personal injury or death.



### **WARNING: Risk of Electrical Shock.**

Ground the actuator according to local, national, and regional regulations. Failure to ground the actuator may result in electrical shock and severe personal injury or death.



### **CAUTION: Risk of Property Damage.**

Do not apply power to the system before checking all wiring connections. Short circuited or improperly connected wires may result in permanent damage to the equipment.

**IMPORTANT:** Make all wiring connections in accordance with local, national, and regional regulations. Do not exceed the electrical ratings of the actuator.

Refer to Figure 8 to wire the applicable M9206-Bxx-2S model.

## Using Conduit

If using conduit or other electrical fittings, refer to Figure 9 and proceed as follows:

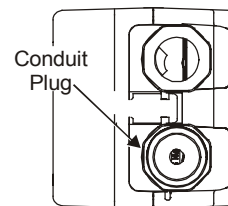

**Figure 9: Bottom of the Actuator**

1. Pry the plastic plug out of the wired conduit opening (if present) with a flat-blade screwdriver.
2. Slide the plug off the wiring cable and discard it.

3. Insert the conduit fitting (not provided) into the 1/2 in. conduit opening, and hand tighten in a CW direction.

**Note:** Use flexible metallic conduit or its equivalent with the conduit fitting.



**WARNING: Risk of Electrical Shock.**

Do not tighten, loosen or otherwise reposition the factory installed conduit adaptor. Tightening, loosening or repositioning may damage or reduce the insulating and strain relief characteristics of the adaptor which can cause electrical shock and may result in severe personal injury or death.

4. Feed the wiring cable through the conduit assembly, and finish wiring.



**WARNING: Risk of Electrical Shock.**

Do not remove the conduit adaptor on the M9206 Series actuator. Removing the adaptor will defeat the double insulation and strain relief features and can result in electrical shock leading to severe personal injury or death.

### Auxiliary Switch (BxB Models)

The M9206-BxB models have a built-in auxiliary switch with a switch adjuster accessible on either face of the actuator. (See Figure 1 and Figure 2.) The factory setting is 20°, nominal. Refer to the *Technical Specifications* section.



**WARNING: Risk of Electrical Shock.**

Insulate and and secure each unused wire lead before applying power to the actuator. Failure to isolate, insulate and secure each unused wire lead may result in property damage, electrical shock, and severe personal injury or death.

The switch point is independently and continuously adjustable from 0 to 90°. For the most accurate positioning of the switch, refer to Figure 10 and use the method in the following example.

To change the trip point:

1. Position the actuator in the full spring return position.

**Note:** The switch is factory set to trip when the actuator reaches the 20° position.

2. Turn the switch adjuster until it points to the desired switch trip point.

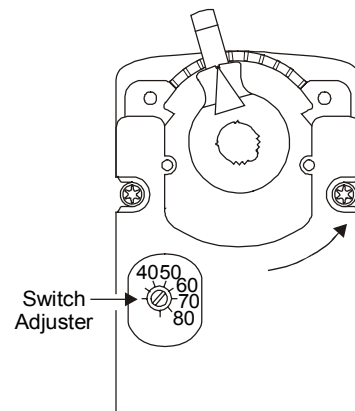

**Figure 10: Switch Trip Point Settings**

3. Connect the switch to a power source or an ohmmeter, and apply power to the actuator. Observe the switch trip point.
4. Turn the adjuster again to reset the trip point, if required.

### Repairs and Replacement

Do not make field repairs. For a replacement or an accessory, refer to the *M9206-Bxx-2S Series On/Off Electric Spring Return Actuators Product Bulletin (LIT-120110)*.

## Technical Specifications

<b>Product</b>	M9206-Bxx-2S Series On/Off Electric Spring Return Actuators	
<b>Power Requirements</b>	Typically:	
	All BGx:	Nominal 9.8 VA running; 5.8 VA holding position
	All BAx:	Nominal 120 V 60 Hz 0.08 A running; 0.05 A holding position
<b>Input Signal</b>	All BGx:	20 to 30 VAC at 50/60 Hz Class 2
	All BAx:	102 to 132 VAC at 60 Hz
<b>Auxiliary Switch Rating</b>	BxB Models:	One Single-Pole, Double-Throw switch
	Rating:	24 VAC: 50 VA pilot duty 120 VAC: 5.8 A resistive, 1/4 hp, 275 VA pilot duty 240 VAC: 5.0 A resistive, 1/4 hp, 275 VA pilot duty
<b>Spring Return</b>	Select the spring return direction by mounting the actuator with: CCW actuator face away from the damper for CCW spring return; CW actuator face away from the damper for CW spring return.	
<b>Mechanical Output</b>	Running Torque:	53 lb-in (6 N·m)
<b>Rotation Range</b>	Adjustable from 34.5 to 90° CW or CCW; mechanically limited to 93°	
<b>Rotation Time</b>	Powered (On):	10 to 40 seconds for 0 to 53 lb-in (0 to 6 N·m) at all operating conditions. 25 seconds nominal for 50% rated load
	Not powered (Off):	Spring return time is 35 seconds nominal, 70 seconds maximum
<b>Cycles</b>	60,000 full stroke cycles; rated at 53 lb-in (6 N·m)	
<b>Audible Noise Rating</b>	55 dBA nominal at 1 m	
<b>Electrical Connections</b>	Actuator:	48 in. (1.2 m) cable with 18 AWG wire leads
	Auxiliary Switch:	48 in. (1.2 m) cable with 18 AWG wire leads
<b>Mechanical Connection</b>	3/8 to 1/2 in. (10.0 to 12.7 mm) diameter round shaft or 3/8 in. (10 mm) square shaft	
<b>Enclosure</b>	NEMA 2, IP42	
<b>Ambient Conditions</b>	Operating:	-25 to 140°F (-32 to 60°C); 10 to 90% RH, noncondensing
	Storage:	-40 to 186°F (-40 to 86°C); 5 to 95% RH, noncondensing
<b>Dimensions (H x W x D)</b>	BGA:	6.98 x 3.25 x 2.99 in. (177.29 x 82.55 x 75.95 mm)
	All Other Models:	8.32 x 3.25 x 2.99 in. (211.33 x 82.55 x 75.95 mm) with conduit adaptor
<b>Shipping Weight</b>	3.45 lb (1.56 kg)	
<b>Agency Compliance</b>	UL Listed, File E27734, CCN XAPX (US) and XAPX7 (Canada)	

The performance specifications are nominal and conform to acceptable industry standards. For application at conditions beyond these specifications, consult the local Johnson Controls office. Johnson Controls, Inc. shall not be liable for damages resulting from misapplication or misuse of its products.



Controls Group  
507 E. Michigan Street  
P.O. Box 423  
Milwaukee, WI 53201

[www.johnsoncontrols.com](http://www.johnsoncontrols.com)