

EFAMS ELECTRONIC FAN INLET & TEMPERATURE MEASUREMENT STATION

APPLICATION

The EFAMS is a highly accurate electronic thermal dispersion type fan inlet air measurement device for reporting air flow and air temperature. The EFAMS transmitter averages multiple velocity and temperature readings from a minimum of two sensors located in the fan inlet bell. The surface mount sensor design ensures the lowest pressure drop in the industry when compared to other after-market fan inlet air measurement devices. Each sensor circuit is equipped with a heated and passive thermistor. Up to four inlet sensors can be connected to one router. The router multiplexes the sensor's air flow and temperature information and sends this as a digital signal to the transmitter for processing. Each Transmitter is capable of averaging two routers and four sensors per router, to arrive at the total measured air flow. The EFAMS transmitter, with two-line, 16 character, configurable display shows both air flow and air temperature with two corresponding, isolated analog outputs, for ease of interface with any automation system.

STANDARD CONSTRUCTION

SURFACE-MOUNT SENSOR ENCLOSURE

Aerodynamically shaped, high impact ABS, with stainless sensor cap. U.L. 94 flame rated housing conforms to the inlet bell contour providing a low profile installation that reduces pressure drop, and saves energy.

SENSOR DISTRIBUTION

Two sensor circuits mounted opposite of each other.

SENSOR CIRCUIT (two standard, up to four per fan location)

Two hermetically sealed, heated thermistors.
Two hermetically sealed, ambient thermistors.

SENSOR ACCURACY

Airflow: $\pm 3\%$.
Temperature: $\pm 0.10^\circ\text{F}$ (0.056°C).

SENSOR RANGES

Airflow Rate: 0-10,000 FPM.
Temperature: -25°F to 140°F (-32°C to 60°C).
Humidity: 0-99% RH, non-condensing.

ROUTER UNIT (one per fan location)

One microprocessor based multiplexer circuit.
Sensor/communications circuit.
All circuits encapsulated in electronic potting compound.

COMMUNICATION CABLE

UL Plenum rated shielded CAT5e network cable (10' [3.05m] standard).
RJ-45 Connectors with dust boot cover and gold plated pins.
Digital interface between router and transmitter.

CONTROL TRANSMITTER

Microprocessor based.
6" x 11³/₈" (152mm x 289mm) nominal control enclosure.
16x2 character LCD display (airflow, temperature & diagnostics).
Seamless "plug & play" connectivity to Router & 2-4 sensor circuits.
24VAC internally fused power supplied by others.
Velocity Output: Field selectable 4-20mA (Std.) or 2-10 VDC using 500 ohm resistor.
Temperature Output: Field selectable 4-20mA (Std.) or 2-10 VDC using 500 ohm resistor.

OPERATING RANGE:

Temperature: -20°F to 120°F (-29°C to 49°C)
Humidity: 0-99% RH, non-condensing

POWER REQUIREMENT

24 VAC transformer.

Dimensions in inches, parentheses () indicate millimeters.



EFAMS (shown on forward curve type fan) with standard Router and Transmitter displays Velocity or flow and Temperature (Fan inlet bell by others)

Refer to Ruskin Installation and Maintenance manual for information on other fan types.

U.S. Patent
7,950,291



FEATURES

- Ruskin thermal dispersion measurement technology provides accurate, repeatable measurement from zero to 10,000 fpm.
- Aerodynamically Shaped, Surface Mount Fan Inlet Sensors
- Multiple-Pivot Living Hinge Design
- LCD Screen on Transmitter
- Shielded CAT5e Cable with RJ-45 Connectors

Ruskin EFAMS helps satisfy the requirements for minimum outside air as required by the following.

- LEED (USGBC)
- ASHRAE 62.1, ASHRAE 90.1 and ASHRAE 189.1.
- California Title 24
- International Mechanical Code (IMC)
- International Energy Conservation Code (IECC)

VARIATIONS

Ruskin model EFAMS is available with the following variations at additional cost.

- Longer communication cables (available in 10' [3.05m] increments up to 50' [15.24m])
- Dual inlet dual density (8 sensors total)
- 120 volt primary/24 volt secondary power transformer shipped loose

CONTENTS & INSTALLATION DETAILS

Please refer to Ruskin EFAMS Installation and Maintenance manual for product application on approved fan types.

Ruskin model EFAMS is a turnkey solution that measures the inlet velocity and temperature of a fan. EFAMS comes complete with a control transmitter (#1) and utilizes thermal dispersion technology to calculate the airflow and average temperature. Two sensor circuits are located opposite one another within the fan inlet bell. An optional four-sensor kit can be ordered for dual inlet fans. Up to four sensor circuits can be installed in one fan inlet bell. The sensor circuit casing (#2) with a stainless steel sensor cap. The sensor circuit casing is mechanically fastened to the inlet bell with pan head, self-drilling fasteners (included in parts bag). The sensor circuit casing has two "living hinges" that enable the device to conform to the shape of the inlet bell for a low profile installation. The Sensor circuit cable (#3) terminates at the router (#4) in RJ45 connectors labeled 1 through 4. Power and communications cables (#5) connect to the router on one end and the control transmitter on the opposite end. The cables are interchangeable. Use one wire to connect P1 to T1 (communications) and the other to connect P2 to T2 (power) as shown in detail A. The sensor readings are multiplexed with a micro-processor and digitally communicated through the communications cable. The router and control transmitter should not be mounted to the fan housing. Install these components on an adjacent structural wall, plenum or ductwork that is isolated from excessive system vibration. Nylon cable clamps (included in parts bag) should be used to secure RJ45 cable between sensors and router, and router and control transmitter. Cable clamps should be spaced on 6" (152mm) centers.

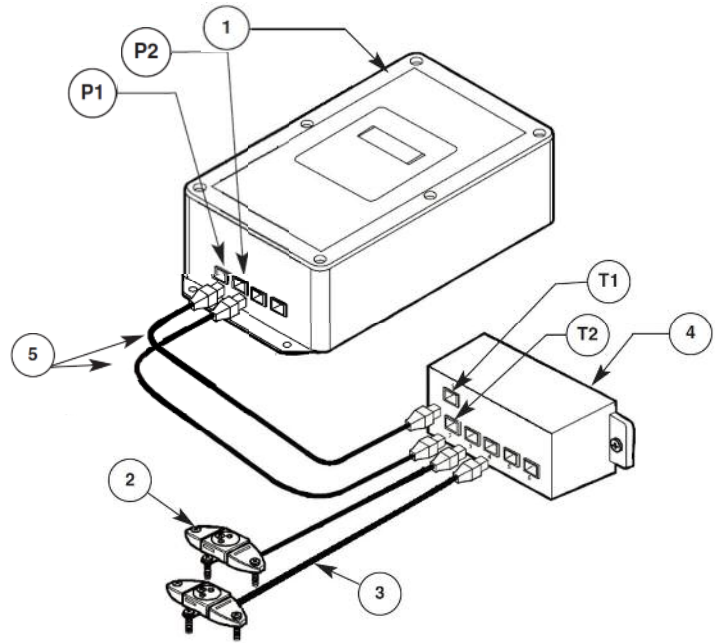

DETAIL A MODEL EFAMS CONTENTS

- | | |
|-------------------------------|-----------------------|
| 1. Transmitter | P1 Communication port |
| 2. Sensor circuit casing | T1 Communication port |
| 3. Sensor circuit cable | P2 Power port |
| 4. Router | T2 Power port |
| 5. Power/communication cables | |

Placement of the sensor housing should be at or near the highest restriction point of the fan inlet as possible. Sensors should be placed at the 12:00 o'clock and 6:00 o'clock positions, or as shown on the cover photo of this document, or directly opposite one another in a similar fashion. On fans with shallow inlet bells, the air leaving side of the sensor housing can be cut off with a box knife, leaving the primary sensor housing (containing the sensor circuit) and the air entering wedge. Utilize the mounting hole on the Primary Sensor Housing when the Air Leaving Wedge is removed (refer to Detail B for clarity).

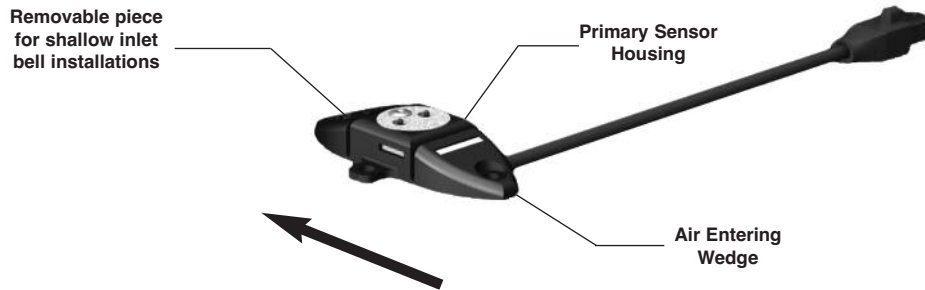

DETAIL B SENSOR HOUSING

WIRING DETAILS

FIELD WIRING CONNECTIONS

1. Connect dedicated 24VAC power to Control Transmitter (30VA).
 - a. Connect 24 VAC hot to +24H terminal
 - b. Connect 24 VAC common to -24C terminal
 - c. Negative (-) terminal to be connected to earth ground
2. Connect 4-20mA velocity and temperature output signal from transmitter to Building Automation System (BAS) noting the polarity indicated on the wiring schematic, using shielded, twisted pair of at least 22 awg. Larger gauge wire may be required for longer runs.
3. Connect sensors to numbered slots on router. Match sensor to port (1, 2, 3, 4).
4. Connect shielded CAT5e network cable between router (T1, T2) and transmitter
5. Turn power switch on

OPERATION

The options menu allows access to reset factory settings, turn LCD on or off, output a test signal to the BAS, change units, enable error indication, adjust gain and offset, set the zero cutoff of the device, display velocity output formula, scale velocity mA output signal and adjust mA output filter value. The up and down buttons on the control panel are used to scroll through the menu options and adjust values.

NORMAL OPERATION

During normal operation the UP and DOWN buttons will scroll through each sensor's velocity and temperature reading. Pressing the ESC button on the control panel will display the average velocity and temperature values. During normal operation two LED's illuminate at the RJ45 connector on the control panel data wire only. The left LED indicates that the control panel has properly identified the router. The right LED illuminates each time the control transmitter communicates with the connected router.

IMPORTANT: The Ruskin Electronic Controller enclosure cover is secured with six Phillips screws. Take care when mounting the electronic controller to ensure there is adequate clearance to remove the cover and make electrical connections in the top of the box.

TECHNOLOGY

Ruskin's Fan Inlet Measurement Station utilizes thermal dispersion technology and greatly reduces static pressure losses.

The mathematically defined relationship between heat transfer rate and airflow velocity make it possible to accurately measure flow by elevating a thermal temperature sensor and placing it in the air-stream with an ambient air temperature sensor as a reference. The heated sensor is elevated to a stipulated temperature differential above the reference point. The velocity is calculated using the reference point (ambient), the known individual heat transfer character-

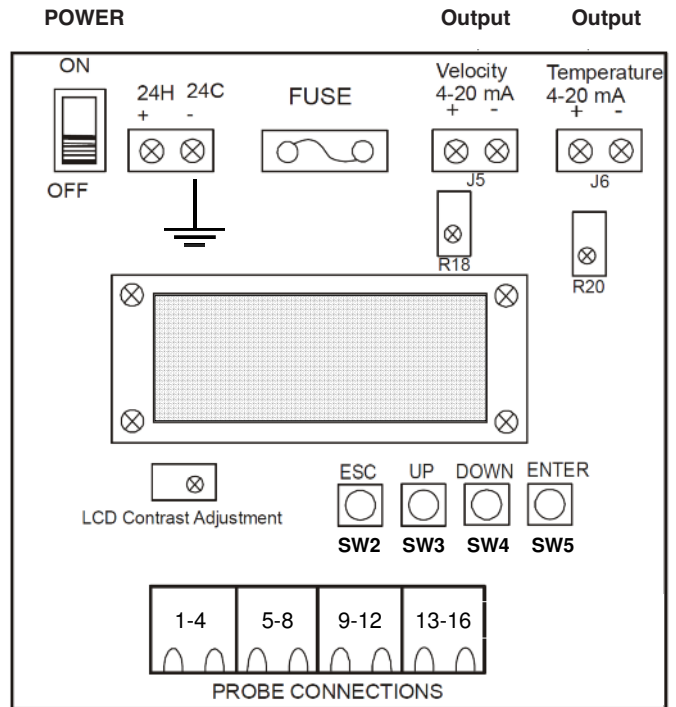

If replacement cables between the router and controller are needed, they must meet the spec for shielded, simple pairing cables.

IMPORTANT: Mount the controller and run the wiring away from variable frequency drives (VFD's) and broadcast antennas. Avoid running this device's wiring in the same conduit as AC power wiring or with wiring used to supply highly inductive loads, such as motors, contactors, and relays.

istics of the calibrated heated sensor, and the power expenditure necessary to maintain the delta between the heated sensor and the ambient reference sensor (ref. Detail C) below.

The aerodynamic shape of the sensor casing, placement of the sensors within the Stainless sensor cap, and surface mount design are just some of the unique features of the Ruskin solution. The pivot points ("living hinges") on the sensor casing allow the unit to conform to the shape of the inlet bell, reducing pressure drop and allowing measurement with nominal fan performance degradation.

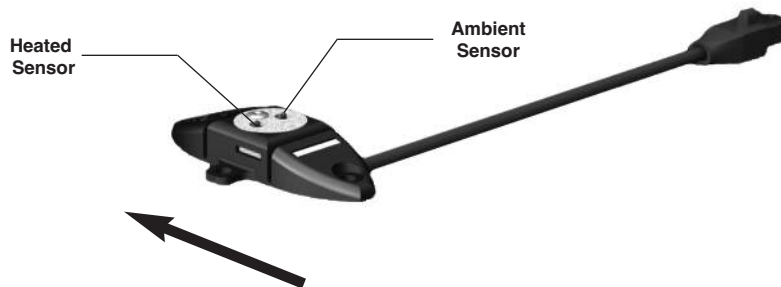

DETAIL C
TYPICAL SENSING CIRCUIT

DIMENSIONAL DETAILS

RUSKIN SENSOR CIRCUIT

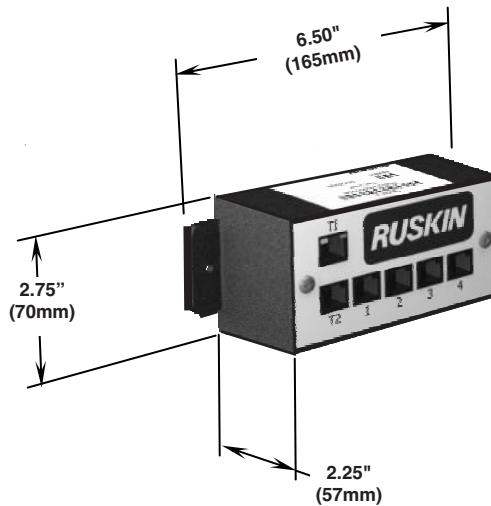
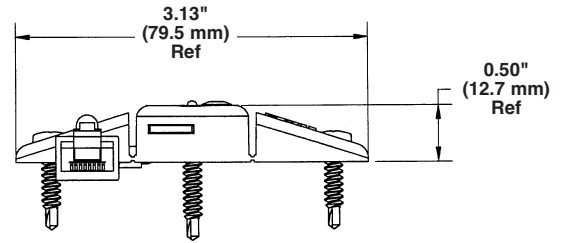
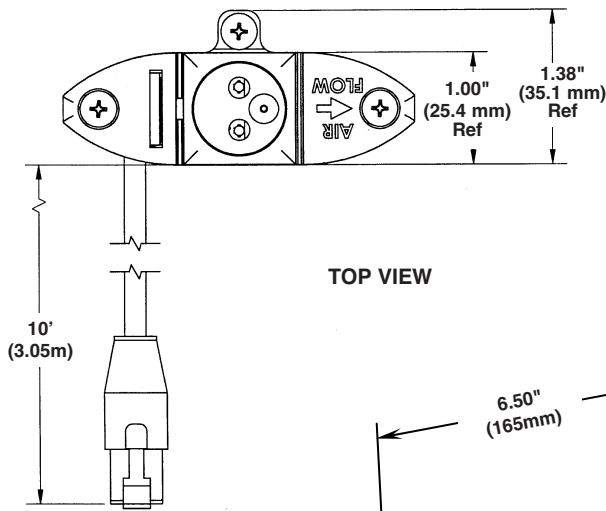

Ruskin Router



Ruskin Control Transmitter

SUGGESTED SPECIFICATION

Furnish and install, at locations shown on plans or as in accordance with schedules, electronic fan inlet airflow and temperature measuring station. Thermal dispersion device shall be surface mount type. Unit shall be capable of monitoring and reporting the airflow and temperature at each fan inlet location through two or four sensing circuits and a control transmitter that communicates with the building automation system (BAS). Sensor circuit casings shall be constructed of U.L. 94 flame rated, high impact ABS and include a stainless steel thermistor cap that maintains the precise calibrated flow over the heated and ambient measurement points. Each sensor circuit shall consist of two glass encapsulated thermistors for measuring ambient temperature and velocity. Circuit shall be designed for operation in a wide range of environments, including high humidity and rapid thermal cycling. Communications cable shall be soldered directly to the printed circuit board to ensure absolute connectivity and long term accuracy. Sensors shall terminate at a router containing a multiplexer circuit. Multiplexer shall include a microprocessor that collects data from each sensor circuit and digitally communicates the average airflow and temperature of sensing point to the microprocessor-based transmitter.

Multiplexer board shall be completely encased in electric potting material to prevent damage. UL Plenum rated, shielded CAT5e communications cable with RJ45 connectors, dust boot covers and gold plated contacts shall link sensors to the router and router to control transmitter. Complete assembly shall be constructed and calibrated in an ISO 9001 certified facility. Communications cable shall be a minimum of 10' (3.05m) in length and shall be available up to 50' (15.24m) when specified. Proprietary cables are not acceptable. Control transmitter shall be capable of processing up to 4 independent sensing points per airflow measuring location and shall operate on a fused 24 VAC supply. Control transmitter shall feature a 16x2 character alphanumeric LCD display, digital offset/gain adjustment, continuous performing sensor/transmitter diagnostics and a visual alarm to detect malfunctions. LCD shall be field adjustable to display either I.P. or S.I. units. Transmitter output shall be field adjustable 4-20 mA or 2-10 VDC. All electronic components of the assembly shall be U.L. rated and RoHS compliant. Performance shall be based on tests and procedures performed in accordance with AMCA Publication 611. Unit shall be in all respects equivalent to Ruskin model EFAMS.



3900 Dr. Greaves Rd.
Kansas City, MO 64030
(816) 761-7476
FAX (816) 765-8955
www.ruskin.com