



INDUSTRIAL CONTROL COMMUNICATIONS, INC.



INVERTER

Plug-in option

FR-A7N-XLT

INSTRUCTION MANUAL

RS485 multiprotocol communication interface



PRE-OPERATION INSTRUCTIONS **1**

INSTALLATION **2**

NETWORK CONNECTION **3**

INVERTER SETTINGS **4**

PROTOCOLS **5**

TROUBLESHOOTING **6**

Thank you for choosing this ICC, Inc. plug-in option for the Mitsubishi 700 Series Inverter. This instruction manual provides handling information and precautions for use of this equipment. Incorrect handling may cause unexpected failures or damage. In order to ensure optimal performance, please read this manual carefully prior to use of the equipment. Please forward this manual to the end user of the equipment.

This section pertains specifically to safety issues

Do not attempt to install, operate, maintain or inspect this product until you have read through this instruction manual and any related documents carefully, and can use the equipment properly. Do not use this product until you have a full working knowledge of the equipment, safety information and instructions. In this instruction manual, the safety instruction levels are classified into "WARNING" and "CAUTION" levels.

WARNING

Assumes that incorrect handling may cause hazardous conditions resulting in death or severe injury.

CAUTION

Assumes that incorrect handling may cause hazardous conditions resulting in moderate or slight injury, or may cause physical damage only.

CAUTION

Please note that even the  level may lead to serious consequence depending on conditions. Please be sure to follow the instructions of both levels as they are critical to personnel safety.

SAFETY INSTRUCTIONS

1. Electrical Shock Prevention

WARNING

- Do not open the front cover of the inverter while power is on or while the inverter is running, as an electrical shock may result.
- Do not operate the inverter with the front cover or wiring cover removed, as accidental contact with exposed high-voltage terminals and internal components may occur, resulting in an electrical shock.
- If power is off, do not remove the front cover except when necessary for wiring or periodic inspection. While the front cover is removed, accidental contact with exposed high-voltage terminals and internal components may occur, resulting in an electrical shock.
- Prior to starting wiring or inspection, confirm that input power to the inverter has been switched off via observation of the inverter's display panel. Additionally, wait for at least 10 minutes after removal of input power, and then confirm that all residual voltage has been dissipated by using a voltage meter. Internal DC bus capacitors may contain high voltages for several minutes after removal of input power, resulting in a dangerous situation should anything come into contact with them.
- All personnel involved in the installation or inspection of this equipment should be fully competent to perform the required work.
- Always install plug-in options prior to wiring main power.
- Do not touch the plug-in option with wet hands.
- Do not subject the cables to scratches, excessive stress, heavy loads or pinching.

2. Injury Prevention



CAUTION

- To prevent explosions or similar damage, apply only the voltages specified in the instruction manual to each terminal.
- To prevent explosions or similar damage, ensure that all cables are properly connected to the correct terminals.
- To prevent explosions or similar damage, observe all wiring polarity indicators.
- To prevent burns from hot components, do not touch the inverter while power is on, or for some time after power is removed.

3. Additional Instructions

Please note the following points to prevent equipment damage, injury or electrical shock.

1) Transportation and Mounting



CAUTION

- Do not install or operate the plug-in option if it is damaged or has parts missing.
- Do not stand on or rest heavy objects on the equipment.
- Check that the mounting orientation is correct.
- Prevent conductive items such as screws and metal fragments, or flammable substances such as oil from entering the inverter.

2) Trial Run



CAUTION

- To prevent unexpected equipment movement, confirm and adjust all required parameters prior to starting operation.

3) Usage



WARNING

- Do not modify the equipment.
- Do not remove any inverter or option parts unless specifically instructed to do so in this manual.



CAUTION

- Performing a “parameter clear” or “all parameter clear” will reset all inverter parameters to their factory default settings. After performing one of these operations, remember to reenter any custom parameter values prior to starting operation.
- To prevent damage from electrostatic discharge, always touch a grounded piece of metal prior to touching any equipment.

4) Maintenance, Inspection and Parts Replacement



CAUTION

- Do not perform hi-pot tests on the equipment.

5) Disposal



CAUTION

- Contact the local or state environmental agency in your area for details on the disposal of electrical components and packaging.

5) General Instructions

For clarity purposes, illustrations in this manual may be drawn with covers or safety guards removed. Ensure all covers and safety guards are properly installed prior to starting operation.

– CONTENTS –

1	PRE-OPERATION INSTRUCTIONS	1
1.1	Product Overview	1
1.2	Unpacking and Product Confirmation	2
1.2.1	Shipment Confirmation	2
1.2.2	Component Overview	3
1.3	LED Indicators	4
1.4	Status LED Error Codes	5
1.5	Environmental Specifications	6
2	INSTALLATION	7
2.1	Pre-Installation Instructions	7
2.2	Installation Procedure	8
2.3	DIP Switch Settings	11
2.3.1	Protocol Selection	12
2.3.2	Baud Rate Selection	12
2.3.3	Parity & Stop Bits Selection	12
2.3.4	2-Wire / 4-Wire Selection	13

3	NETWORK CONNECTION	14
<hr/>		
3.1	Metasys N2 Connections	14
3.2	Siemens FLN Connections	15
3.3	BACnet MS/TP Connections	16
3.4	Modbus RTU Connections	17
3.5	RS485 Port Electrical Interface	20
3.6	Wiring	21
4	INVERTER SETTINGS	22
<hr/>		
4.1	RS-485 Communication Settings	23
4.1.1	RS-485 Communication Station (Pr. 331).....	23
4.1.2	RS-485 Communication Speed (Pr. 332)	24
4.1.3	RS-485 Communication Parity Check Selection (Pr. 334)	24
4.1.4	Protocol Selection (Pr. 549)	25
4.1.5	Free Parameter 1 (Pr. 888)	25
4.1.6	Free Parameter 2 (Pr. 889)	26
4.2	Operation Mode Setting	27
4.2.1	Operation Mode Indication	27
4.2.2	Operation mode switching & comm. startup mode (Pr. 79, Pr. 340)	28
4.3	Operation & Speed Command Source (Pr.338, Pr.339, Pr.550)	32
4.4	Communication EEPROM write selection (Pr. 342)	36

5 PROTOCOLS **37**

5.1 Johnson Controls, Inc. Metasys N2	37
5.1.1 Node Addressing.....	37
5.1.2 Network Characteristics	38
5.1.3 Object Summaries.....	38
5.1.4 Supported Objects.....	40
5.2 Siemens FLN	44
5.2.1 Node Addressing.....	44
5.2.2 Network Characteristics	44
5.2.3 Supported Subpoints.....	45
5.2.4 Subpoint Details	48
5.3 BACnet MS/TP	57
5.3.1 Station Addressing	57
5.3.2 Network Characteristics	57
5.3.3 Protocol Implementation Conformance Statement	57
5.3.4 Supported Objects.....	64
5.4 Modbus RTU	69
5.4.1 Node Addressing.....	69
5.4.2 Network Characteristics	69
5.4.3 Supported Functions	69
5.4.4 Register Addressing.....	70
5.4.5 Coil & Discrete Input Mappings.....	71

1 PRE-OPERATION INSTRUCTIONS

1.1 Product Overview

The FR-A7N-XLT RS485 multiprotocol communication interface allows the 700-series inverter into which it is installed to communicate on networks using the following protocols:

- ▶ Johnson Controls, Inc. Metasys® N2
- ▶ Siemens FLN
- ▶ BACnet MS/TP
- ▶ Modbus RTU

The option card mounts directly onto the inverter's control board, and communicates to the inverter via its built-in RS485 communication port, located in the upper-left hand corner of the inverter's control board. Note that because the inverter's RS485 port is used by the FR-A7N-XLT card, it is therefore unavailable for use by any other network when the FR-A7N-XLT interface is installed.

Before using the option card, please familiarize yourself with the product and be sure to thoroughly read the instructions and precautions contained in this manual. In addition, please make sure that this instruction manual is delivered to the end user of the option card, and keep this instruction manual in a safe place for future reference or unit inspection.

The FR-A7N-XLT can be connected to either 2-wire or 4-wire RS485 networks, selectable via DIP switch settings. Protocol selection, etc. is also configured via DIP switch settings, while the inverter's network station address is configured via an inverter parameter setting.



1.2 Unpacking and Product Confirmation

1.2.1 Shipment Confirmation

Check the enclosed items. Confirm that the correct quantity of each item was received, and that no damage occurred during shipment.



Plug-in option (P/N 10620A): qty. 1



RS485 cable (P/N 10621): qty. 1



Hex-head standoff (5.5mm): qty. 1



Mounting screws (M3 x 6mm): qty. 2

1.2.2 Component Overview

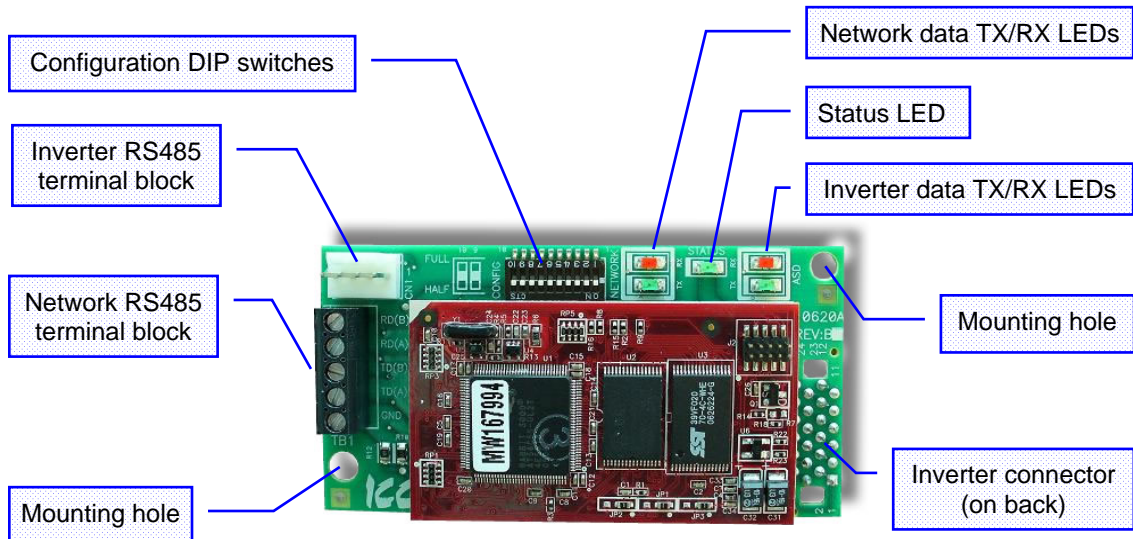

1



1.3 LED Indicators

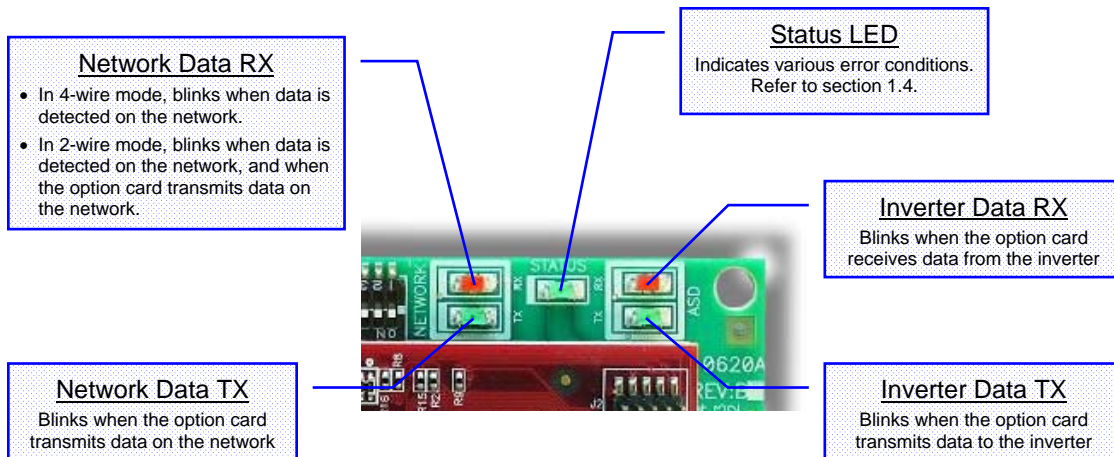

1.4 Status LED Error Codes

The green “status” LED provides an indication of the option card’s health & configuration. Typically, this LED should be solid green, which indicates that the card has a valid configuration and that it is operating normally.

If an invalid configuration or some other hardware error is detected, then the status LED will emit a sequence of short blinks. Each sequence of short blinks is terminated by 2s of continuous off time, after which the sequence repeats. The error code is indicated by counting the number of short blinks.

1

Refer to the following table for a list of the possible error codes.

Error Code	Explanation
1	INVALID ADDRESS: an invalid network station address is entered in <i>Pr. 889 Free parameter 2</i> . Refer to section 4.1.6.
2	INVALID PROTOCOL: an invalid protocol has been selected. Refer to section 2.3.1.
3	RESOURCE ALLOCATION ERROR: an internal resource error has been detected. Contact ICC technical support for assistance.
4	INVALID BAUD RATE: BACnet MS/TP cannot operate at 4800 baud. Select a valid BACnet baud rate.

To clear the error, correct the cause of the error and cycle power to the inverter to reset the option card.



1.5 Environmental Specifications

Item	Specification
Operating Environment	Indoors, less than 1000m above sea level, do not expose to direct sunlight or corrosive / explosive gasses
Operating Temperature	-10 ~ +50°C (+14 ~ +122°F)
Storage Temperature	-40 ~ +85°C (-40 ~ +185°F)
Relative Humidity	20% ~ 90% (without condensation)
Vibration	5.9m/s ² (0.6G) or less (10 ~ 55Hz)
Grounding	Referenced to inverter RS485 secondary / isolated from inverter control power common
Power supply	Supplied from inverter
Cooling Method	Self-cooled
Communication Speed	4800 / 9600 / 19200 / 38400 baud



The FR-A7N-XLT interface is lead-free / RoHS-compliant.

2 INSTALLATION

2.1 Pre-Installation Instructions

Make sure that the inverter's input power is off.



CAUTION



To avoid damage to the inverter or plug-in option card, never install or remove a plug-in option card while the inverter's input power is on.

2

Physical installation of the option card is a two-step process. First, the card will be mounted onto an available option connector on the inverter's control board. Second, the card will be connected to the inverter's RS485 communication port via the included #10621 RS485 cable.



2.2 Installation Procedure

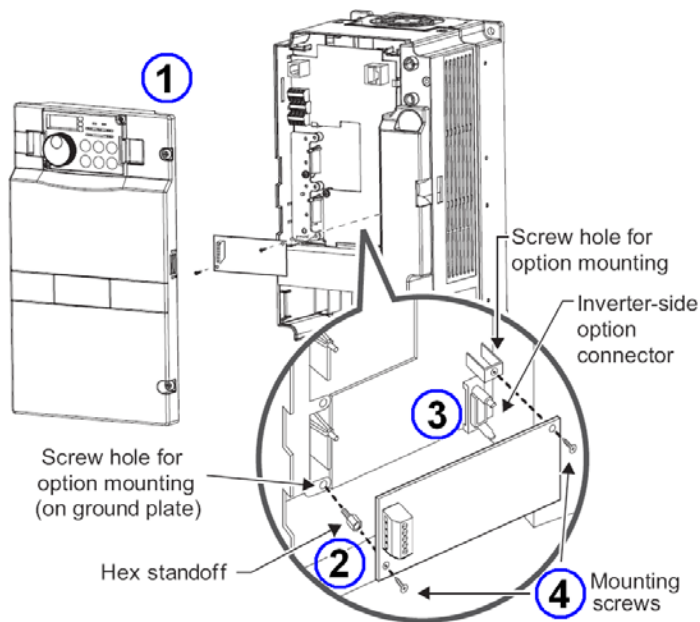

1) Remove the inverter's front cover.

2) Locate an open option connector and screw the included 5.5mm hex standoff into the corresponding ground plate screw hole (rated torque 0.56N·m to 0.75N·m).

3) Securely attach the option card to the inverter's option connector. Ensure that the option card is fully seated on the inverter's option connector and the hex standoff.

4) Secure the upper-right and lower-left corners of the option card with the included M3x6mm mounting screws. If the screw holes do not line up, the option card connector may not be fully seated on the inverter's option connector and the hex standoff.

5) Connect the stripped-wire end of the #10621 RS485 cable to the inverter's RS485 terminal blocks, and set the termination switch located on the inverter's control board to the "OPEN" position. Each of the wires is individually labeled with the name of the terminal signal to which they must be connected, and are pre-stripped for ease of installation. Connect the TXD+ (green) and TXD- (white) wires to the "TXD" terminal block, positions 1 & 2, respectively. Then connect the RXD+ (black) and RXD- (red) wires to the "RXD" terminal block, positions 1 & 2, respectively. Refer to the following picture for a post-connection view of the wiring connections.

**2**

INSTALLATION

6) Connect the 4-position plug end of the #10621 RS485 cable to connector CN1 in the upper-left corner of the option board. Note that the connector is keyed to prevent the possibility of reverse installation. Refer to the following picture for a post-connection view.

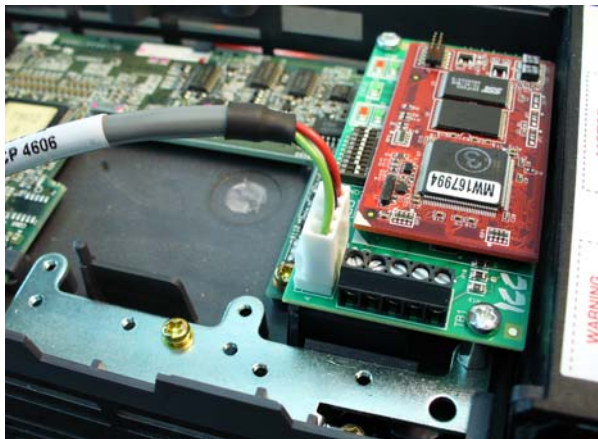

REMOVAL

First disconnect the #10621 RS485 cable from connector CN1 on the option board. Next, remove the two M3x6mm mounting screws. Lastly, remove the option board by grasping it on its left and right side and pulling it straight away from the inverter. Note that the removal process may be easier by first removing the inverter's control circuit terminal block.

2.3 DIP Switch Settings

The option board has a 10-position DIP switch located at the top of the board that is used for network configuration. The “ON” position of the DIP switch is down (toward the bottom of the inverter), and the “OFF” position is up (toward the top of the inverter). The switch functions are assigned as follows:

- Switches #1 ~ #3network protocol selection
- Switches #4 & #5network baud rate (ignored for N2 and FLN protocols)
- Switches #6 & #7network parity & stop bits (ignored for N2, FLN and BACnet protocols)
- Switch #8reserved
- Switches #9 & #10network 2-wire / 4-wire selection

Note that DIP switches #1 ~ #8 are read by the option card only on power-up. Therefore, if the switch positions are changed while the inverter is powered, then the inverter must be powered off and then back on again to force the option card to detect the new switch positions.

DIP switches #9 and #10 modify the hardware connections on the option board, and changes to these switches therefore do not require power to the inverter to be cycled.



2.3.1 Protocol Selection

Switch #3	Switch #2	Switch #1	Protocol
Off	Off	Off	Metasys N2
Off	Off	On	Siemens FLN
Off	On	Off	Modbus RTU
Off	On	On	BACnet MS/TP

- Any other settings for switches #1 ~ #3 will result in an “invalid protocol” error upon startup (refer to section 1.4)

2.3.2 Baud Rate Selection

Switch #5	Switch #4	Baud Rate
Off	Off	38400
Off	On	19200
On	Off	9600
On	On	4800

- The baud rate selection switches are ignored when either the N2 or FLN protocols are active, as the drivers for these protocols use a fixed baud rate required by their respective specifications.
- 4800 baud is not valid for BACnet MS/TP.

2.3.3 Parity & Stop Bits Selection

Switch #7	Switch #6	Parity	Stop Bits
Off	Off	None	1
Off	On	Odd	1
On	Off	Even	1
On	On	None	2

- The parity & stop bits selection switches are ignored when the N2, FLN and BACnet MS/TP protocols are active, as the drivers for these protocols use a fixed configuration required by their respective specifications.

2.3.4 2-Wire / 4-Wire Selection

Switches #9 and #10 determine whether the RS485 network being connected to terminal block TB1 is a 2-wire (half duplex) or 4-wire (full duplex) network. If your RS485 network contains 5 wires (4 signal wires + GND), then place both switches in the “FULL” (up) position. If your RS485 network contains only 3 wires (2 signal wires + GND), then place both switches in the “HALF” (down) position. Note that both switches must always be in the same position (i.e. both in “FULL” or both in “HALF”) for network communication to occur. As a visual reminder, there is a helper pictogram on the board’s silkscreen to the immediate left of switches #9 and #10 to assist in the positioning of these switches.

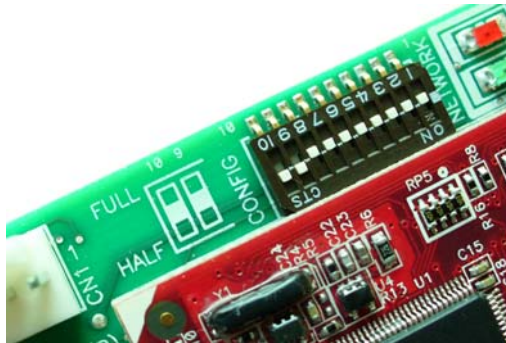
2



3 NETWORK CONNECTION

The RS485 network connects to screw terminal block TB1 located on the left side of the option card. The specific connection scheme will depend on the network you are connecting to, and will involve both physical termination of the wires to the terminal block, as well as appropriate selection of the 2-wire/4-wire DIP switches (refer to section 2.3.4). In general, there is no universal standardized labeling scheme for RS485 signal connections, so other equipment on your network may use labels such as “+” and “-” or “S1” and “S2”, etc. In such instances, the correct connection scheme is usually intuitive (e.g. in FLN installations, connection “+” to “RD(A)” and “-” to “RD(B)”), or typically can be obtained via trial and error by simply swapping the signal wires if no communication can initially be achieved.

3.1 Metasys N2 Connections

METASYS® IS A REGISTERED TRADEMARK OF JOHNSON CONTROLS, INC.

Terminal block TB1 can be directly connected to the N2 bus by using twisted-pair cable connected as shown in Figure 1. Place the 2-wire/4-wire DIP switches in the “HALF” position, then connect the “N2+” wire to terminal “RD(A)” and the “N2-” wire to terminal “RD(B)”. Although not available on all devices, it is also strongly recommended to connect a network ground wire whenever possible. Continue this connection scheme throughout the remainder of the network. Always connect each unit in a daisy-chain fashion, without drop lines, star configurations, etc. For further N2 network wiring requirements and procedures, please refer to the appropriate JCI network installation documentation.

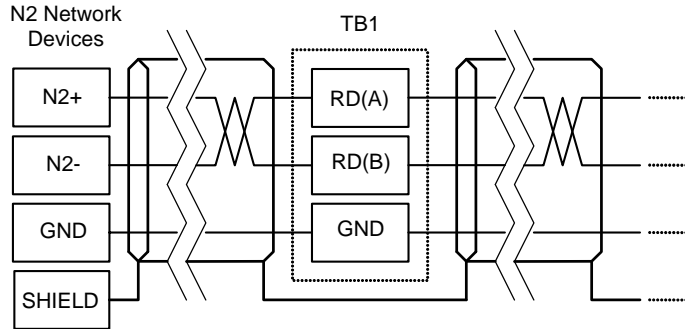

Figure 1: N2 Network Connections

3.2 Siemens FLN Connections

APOGEE® FLN IS A REGISTERED TRADEMARK OF SIEMENS BUILDING TECHNOLOGIES, INC.

Terminal block TB1 can be directly connected to the FLN bus by using twisted-pair cable connected as shown in Figure 2. Place the 2-wire/4-wire DIP switches in the “HALF” position, then connect the “+” wire to terminal “RD(A)” and the “-” wire to terminal “RD(B)”. Although not available on all devices, it is also strongly recommended to connect a network ground wire whenever possible. Continue this connection scheme throughout the remainder of the network. Always connect each unit in a daisy-chain fashion, without drop lines, star configurations, etc. For further FLN network wiring requirements and



procedures, please refer to the appropriate Siemens Building Technologies network installation documentation.

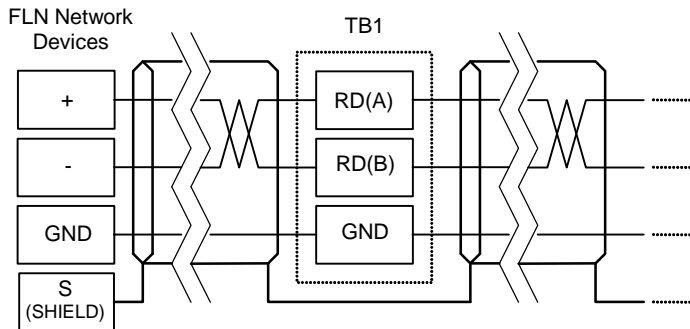

Figure 2: FLN Network Connections

3.3 BACnet MS/TP Connections

Terminal block TB1 can be directly connected to the BACnet bus by using twisted-pair cable connected as shown in Figure 3. Place the 2-wire/4-wire DIP switches in the “HALF” position, then connect the “A” or “+” wire to terminal “RD(A)” and the “B” or “-“ wire to terminal “RD(B)” (note that terminal labeling may vary among BACnet device vendors). Although not available on all devices, it is also strongly recommended to connect a network ground wire whenever possible. Continue this connection scheme throughout the remainder of the network. Always connect each unit in a daisy-chain fashion, without

drop lines, star configurations, etc. For further BACnet network wiring requirements and procedures, please refer to the appropriate BACnet network installation documentation.

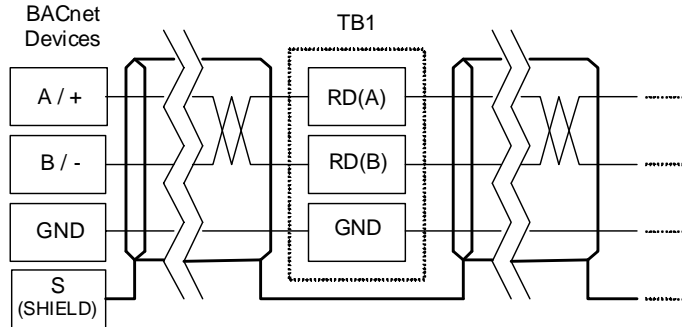

Figure 3: BACnet MS/TP Network Connections

3.4 Modbus RTU Connections

The topologies, connection methods and terminal labeling of Modbus RTU networks can vary greatly. In general, however, two basic topologies exist: 2-wire and 4-wire. In either case, terminal block TB1 can be directly connected to the Modbus RTU network by using twisted-pair cable connected as shown below.



For a 2-wire network topology, place the 2-wire/4-wire DIP switches in the “HALF” position, choose the appropriate baud rate, parity & stop bits (refer to section 2.3), then connect the “A” wire to terminal “RD(A)” and the “B” wire to terminal “RD(B)” as shown in Figure 4.

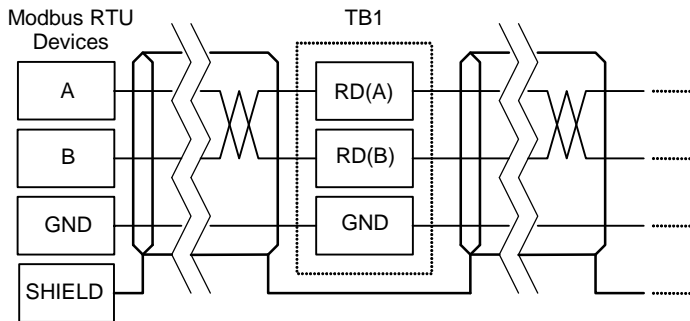

Figure 4: 2-Wire Modbus RTU Network Connections

For a 4-wire network topology, place the 2-wire/4-wire DIP switches in the “FULL” position, choose the appropriate baud rate, parity & stop bits (refer to section 2.3), then connect the “A” wire to terminal “RD(A)”, the “B” wire to terminal “RD(B)”, the “Y” wire to terminal “TD(A)”, and the “Z” wire to terminal “TD(B)”. Refer to Figure 5.

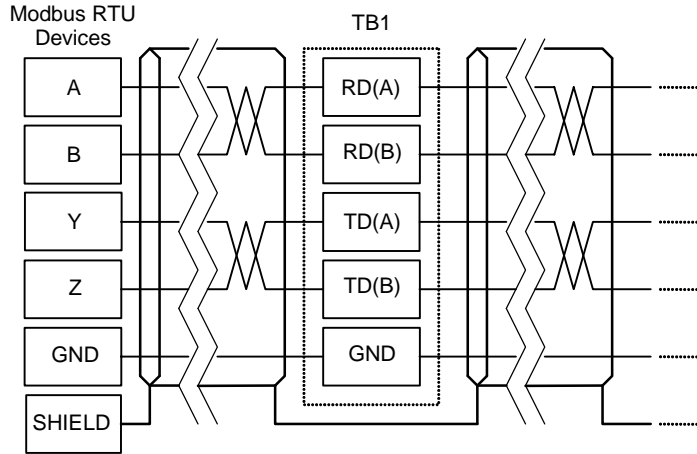

Figure 5: 4-Wire Modbus RTU Network Connections

Although not available on all devices, it is also strongly recommended to connect a network ground wire whenever possible. Continue the 2-wire or 4-wire connection scheme throughout the remainder of the network. Always connect each unit in a daisy-chain fashion, without drop lines or star configurations, etc. For further Modbus network wiring requirements and procedures, please refer to the appropriate Modbus network installation documentation.



3.5 RS485 Port Electrical Interface

In order to ensure appropriate network conditions (signal voltage levels, etc.) when connecting an RS485 network to the option card's RS485 port (TB1), some knowledge of the network interface circuitry is required. Refer to the following figure for a simplified schematic of the RS485 interface circuitry.

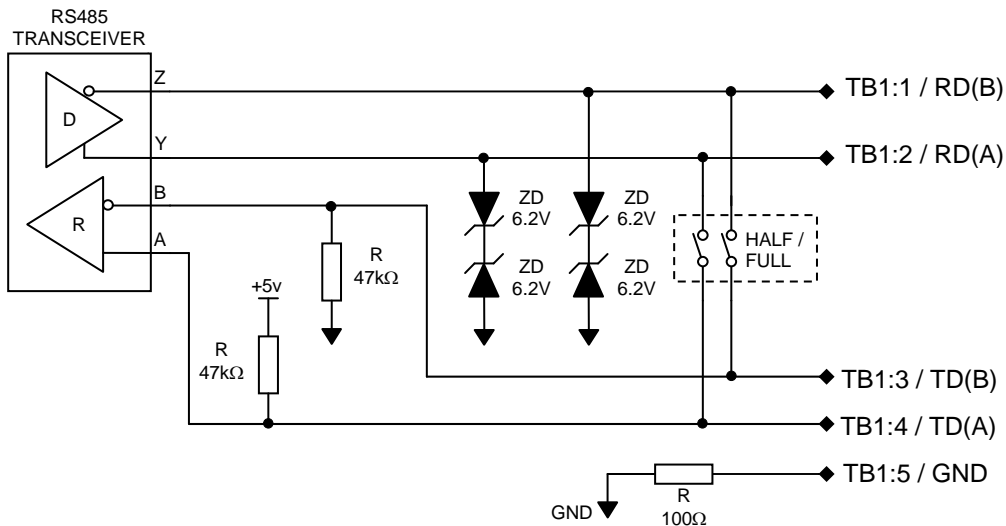

3.6 Wiring

When installing the option card into an FR-A720-00900-NA (FR-A740-00440-NA) or smaller inverter, remove the wiring access knockout on the front cover and route the network cable through the opening. When installing the option card into an FR-A720-01150-NA (FR-A740-00570-NA) or larger inverter, route the network cable through the space adjacent to the control circuit terminal block.

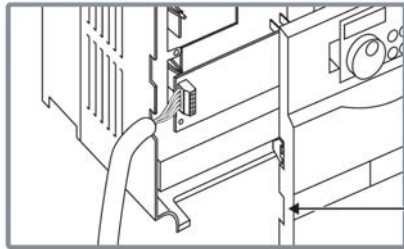

FR-A720-00900-NA (FR-A740-00440-NA)
and smaller

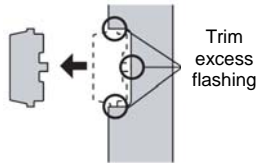

Remove front cover wiring access knockout and trim any excess flashing that may cause cable damage

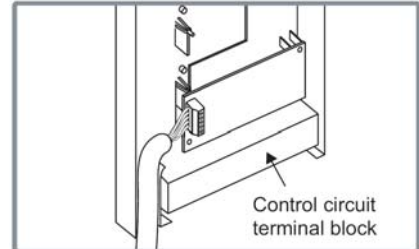

FR-A720-01150-NA (FR-A740-00570-NA)
and larger

NOTE: If the front cover wiring access knockout is removed, the protective structure (JEM1030) changes to open type (IP00).

CAUTION

 Use caution during wiring to prevent any cable fragments and wire strands from falling into the inverter. Equipment damage may result if power is applied to the inverter in the presence of conductive debris.



4 INVERTER SETTINGS

The inverter parameters listed in the following table are critical for overall operation of the end-to-end communication system. Some of these parameters must be set to specific values, and some may have multiple allowable settings depending on the desired operation of the overall application. Although there may be many other inverter parameters that will require configuration for your specific application, it is important to understand the manner in which the following parameters will impact successful communications with, and control of the inverter.

Parameter Number	Name	Setting Range	Default Value	Refer to Page
79	Operation mode selection	0 to 4, 6, 7	0	28
331	RS-485 communication station	0 to 247	0	23
332	RS-485 communication speed	3, 6, 12, 24, 48, 96, 92, 384	96	24
334	RS-485 communication parity check selection	0 to 2	2	24
338	Communication operation command source	0, 1	0	33
339	Communication speed command source	0, 1, 2	0	33
340	Communication startup mode selection	0, 1, 2, 10, 12	0	28
342	Communication EEPROM write selection	0, 1	0	36
549	Protocol selection	0, 1	1	25
550	NET mode control source selection	0, 1, 9999	9999	32
888	Free parameter 1	0 to 9999	9999	25
889	Free parameter 2	0 to 9999	9999	26

4.1 RS-485 Communication Settings

Because the FR-A7N-XLT option card communicates with the inverter via the inverter's on-board RS-485 port, certain RS-485 -related inverter parameters must be set appropriately in order to allow the option card to successfully exchange data with the inverter. If any one of these parameters is not correctly configured, the FR-A7N-XLT card will not be able to communicate with the inverter.

REMARKS

Whenever any of the RS-485 communication setting parameters is changed, power to the inverter must be cycled to validate the changes and allow the inverter to begin communicating at the new settings.

4.1.1 RS-485 Communication Station (Pr. 331)

Typically, *Pr. 331* would set the inverter's station number on the network. When using the FR-A7N-XLT option card, however, *Pr. 331* must be set to a known value so that the option card can communicate with the inverter independent of the outside network's station number configuration. In this situation, therefore, the inverter's station number on the network is actually set by *Pr. 889* (refer to section 4.1.6.)

4

Parameter Number	Name	Default Value	Setting Range	Description
331	RS-485 communication station	0	0 to 247	Must be set to a value of "1" in order to allow the option card to communicate with the inverter.



4.1.2 RS-485 Communication Speed (Pr. 332)

Pr. 332 determines the data rate at which the option card will communicate with the inverter. Note that this data rate is not related to the data rate that the option card will use when communicating to the outside network (which is set via DIP switches on the option card: refer to section 2.3.2.)

Parameter Number	Name	Default Value	Setting Range	Description
332	RS-485 communication speed	96	3, 6, 12, 24, 48, 96, 92, 384	Must be set to a value of "384" (38.4kbaud), which will allow the option card to communicate with the inverter at the fastest possible rate.

4.1.3 RS-485 Communication Parity Check Selection (Pr. 334)

Pr. 334 determines the parity & stop bit(s) which the inverter and option card will use when communicating with each other. Note that this setting is not related to the parity & stop bit(s) that the option card will use when communicating to the outside network (which may be either pre-determined by the chosen protocol, or set via DIP switches on the option card: refer to section 2.3.3 and the protocol-specific explanation portions of this manual for further information.)

Parameter Number	Name	Default Value	Setting Range	Description
334	RS-485 communication parity check selection	2	0 to 2	Must be set to a value of "2" (even parity, 1 stop bit)

4.1.4 Protocol Selection (Pr. 549)

Pr. 549 determines whether the inverter’s RS-485 port will communicate using the Mitsubishi computer-link protocol, or the Modbus RTU protocol (default). Note that this protocol selection is not related to the protocol that the option card will use when communicating to the outside network (which is set via DIP switches on the option card: refer to section 2.3.1.)

Parameter Number	Name	Default Value	Setting Range	Description
549	Protocol selection	1	0, 1	Must be set to a value of “1” to enable the option card to communicate to the inverter via the Modbus RTU protocol.

4.1.5 Free Parameter 1 (Pr. 888)

Pr. 888 sets the device instance number that the inverter will use when connected to a BACnet network. Note that Pr. 888 is not used with any other network.

Parameter Number	Name	Default Value	Setting Range	Description
888	Free parameter 1	9999	0 to 9999	Sets the device instance number, which must be unique across the entire BACnet network because it is used to uniquely identify BACnet devices.

REMARKS

Whenever *Pr. 888* is changed, the new value can only be detected by the option card by cycling power to the inverter. In other words, resetting the inverter after a fault, etc. will not transfer the new value to the option card, as *Pr. 888* is read by the option card only when it (and the inverter) initially powers up.

4.1.6 Free Parameter 2 (*Pr. 889*)

Pr. 889 sets the station number that the inverter will reside at on the outside network. Note that *Pr. 331* is not used to set the outside network station number (refer to section 4.1.1.)

Parameter Number	Name	Default Value	Setting Range	Description
889	Free parameter 2	9999	0 to 9999	Valid network station numbers vary depending on the selected protocol. Refer to the protocol-specific explanation portions of this manual for further information.

REMARKS

Whenever *Pr. 889* is changed, the new value can only be detected by the option card by cycling power to the inverter. In other words, resetting the inverter after a fault, etc. will not transfer the new value to the option card, as *Pr. 889* is read by the option card only when it (and the inverter) initially powers up.

4.2 Operation Mode Setting

Three operation modes are available when a communication option card is installed into an inverter.

1. PU operation [PU] The inverter is controlled by the operating panel (FR-DU07).
2. External operation [EXT] ... The inverter is controlled by the ON/OFF switching of external signals connected to the control circuit terminals (factory default.)
3. Network operation [NET] ... The inverter is controlled from the network via the communication option card (the operating commands and frequency command can be input via the control circuit terminals depending on the settings of Pr. 338 *Communication operation command source* and Pr. 339 *Communication speed command source*. Refer to page 33.)

4.2.1 Operation Mode Indication

FR-DU07

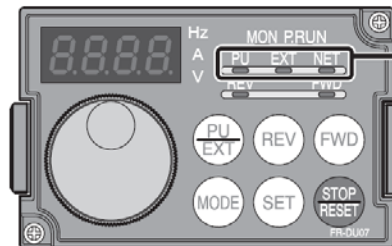

Operation mode indication (the inverter operates in accordance with the indicated LED.)

PU: PU operation mode

EXT: External operation mode

NET: Network operation mode



4.2.2 Operation mode switching & comm. startup mode (Pr. 79, Pr. 340)

(1) Operation mode switching conditions

Prior to switching the operation mode, confirm that:

- 1) The inverter is stopped
- 2) Both the STF and STR signals are off
- 3) The *Pr. 79 Operation mode selection* setting is correct. Refer to the appropriate inverter *user's manual (applied)* for further information regarding *Pr. 79*.

(2) Operation mode selection at power on and after recovery from a momentary power failure

The operation mode at power on and after recovery from a momentary power failure can be selected via *Pr. 340*. A value other than "0" will select network operation mode. After activating network operation mode, parameter writes from the network are enabled.

REMARKS

1. When *Pr. 340* is changed, the new setting is validated after powering on or resetting the inverter.
2. *Pr. 340* can be changed via the operation panel regardless of the operation mode.

Pr. 340 Setting	Pr. 79 Setting	Operation Mode at Power-On or Power Recovery	Operation Mode Switchover
0 (default)	0 (default)	External operation mode	Switching among external, PU, and NET operation modes is enabled ¹
	1	PU operation mode	PU operation mode fixed
	2	External operation mode	Switching between external and NET operation modes is enabled, switching to PU operation mode is disallowed
	3, 4	External/PU combined operation mode	Operation mode switching is disallowed
	6	External operation mode	Switching among external, PU, and NET operation modes is enabled while running.
	7	X12 (MRS) signal ON.....external operation mode	
X12 (MRS) signal OFF...external operation mode			External operation mode fixed (forcibly switched to external operation mode.)
1, 2 _{1,2}	0	NET operation mode	Same as when Pr. 340 = "0"
	1	PU operation mode	
	2	NET operation mode	
	3, 4	External/PU combined operation mode	
	6	NET operation mode	
	7	X12 (MRS) signal ON....NET operation mode	
X12 (MRS) signal OFF...external operation mode			
10, 12 _{1,2}	0	NET operation mode	Switching between PU and NET operation modes is enabled ³
	1	PU operation mode	Same as when Pr. 340 = "0"
	2	NET operation mode	NET operation mode fixed
	3, 4	External/PU combined operation mode	Same as when Pr. 340 = "0"
	6	NET operation mode	Switching between PU and NET operation modes is enabled while running ³
	7	External operation mode	Same as when Pr. 340 = "0"

¹ The operation mode can not be directly changed between PU mode and NET mode.



² *Pr. 340* settings "2" and "12" are mainly used for communication operation using the inverter's RS-485 port. When a value other than "9999" (automatic restart after momentary power failure) is set in *Pr. 57 Restart coasting time*, the inverter will resume the same operation state which it was in prior to a momentary power failure if such a failure occurs. When *Pr. 340* is set to "1" or "10" and a start command is active, then the start command will be deactivated if a momentary power failure occurs.

³ The operation mode can be changed between PU mode and NET mode with the  key on the operating panel (FR-DU07) and X65 signal.

(3) Operation mode switching method

When "0, 1, or 2" is set in Pr. 340

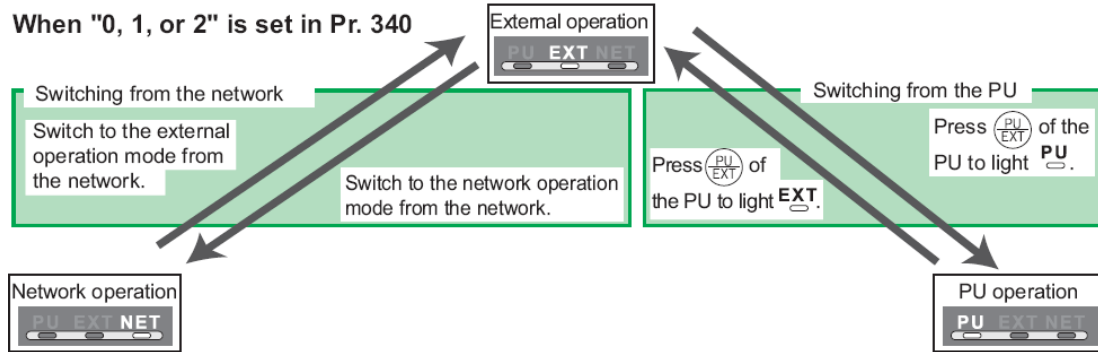

When "10 or 12" is set in Pr. 340

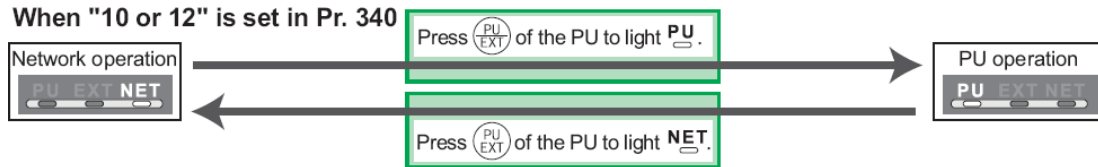

For a switching method via external terminal input signals, refer to the inverter's *user's manual* (applied).



- When starting the inverter in NET mode upon powering-up or after an inverter reset, set a value other than 0 in Pr. 340. (Refer to page 28).
- When setting a value other than 0 in Pr. 340, make sure that the initial settings of the inverter are correct.



4.3 Operation & Speed Command Source (Pr.338, Pr.339, Pr.550)

(1) Select control source for NET mode (Pr. 550)

The control location for NET mode can be selected to be from either the inverter's RS-485 port or a plug-on communication option card. Although the FR-A7N-XLT card physically plugs into the inverter's option card slot, it actually communicates to the inverter via the inverter's RS-485 port. Therefore, to control the inverter via the FR-A7N-XLT card, Pr. 550 must be set to either "9999" (default) or "1" (RS-485 input valid).

Parameter Number	Name	Default Value	Setting Range	Description
550	NET mode operation command source selection	9999	0	Communication option card control is valid (FR-A7N-XLT control via the inverter's RS-485 port is invalid.)
			1	FR-A7N-XLT control via the inverter's RS-485 port is valid (communication option card control is invalid.)
			9999	Communication option automatic recognition. Normally, control via the inverter's RS-485 port is valid, which includes the situation when an FR-A7N-XLT card is installed. When a non-FR-A7N-XLT communication option card is installed, that communication option card's control is made valid instead of the inverter's RS-485 port.

Refer to the inverter's *user's manual (applied)* for further details.

(2) Selection of control source for NET mode (Pr. 338, Pr. 339)

Control sources can be subdivided into two separate realms: 1) operation commands such as start/stop signals, etc. and 2) the speed command source that determines the inverter's frequency command. The various combinations of these realms that can be configured are summarized in the following table.

Control Location Selection	Pr. 338 Communication operation command source		0:NET			1:External			Remarks	
	Pr. 339 Communication speed command source		0:NET	1: External	2: External	0:NET	1: External	2: External		
Fixed functions (Functions equivalent to terminals)	Running frequency from communication		NET	—	NET	NET	—	NET		
	Terminal 2		—	External	—	—	External	—		
	Terminal 4		—	External		—	External			
	Terminal 1		Compensation							
Selective functions Pr. 178 to Pr. 189 settings	0	RL	Low-speed operation command/remote setting clear		NET	External		NET	External	Pr. 59 = "0" (multi-speed) Pr. 59 = "1, 2" (remote)
	1	RM	Middle-speed operation command/remote setting deceleration		NET	External		NET	External	
	2	RH	High-speed operation command/remote setting acceleration		NET	External		NET	External	
	3	RT	Second function selection		NET		External			
	4	AU	Terminal 4 input selection		—	Combined		—	Combined	
	5	JOG	Jog operation selection		—		External			
	6	CS	Automatic restart after instantaneous power failure selection		External					
	7	OH	External thermal relay input		External					
	8	REX	15-speed selection		NET	External		NET	External	Pr. 59 = "0" (multi-speed)
	9	X9	Third function		NET			External		
10	X10	Inverter operation enable signal		External						



Control Location Selection	Pr. 338 Communication operation command source		0:NET			1:External			Remarks	
	Pr. 339 Communication speed command source		0:NET	1: External	2: External	0:NET	1: External	2: External		
Selective functions Pr. 178 to Pr. 189 settings	11	X11	FR-FC connection, instantaneous power failure detection		External					
	12	X12	PU operation external interlock		External					
	13	X13	External DC injection brake operation is started		NET		External			
	14	X14	PID control valid terminal		NET	External		NET	External	
	15	BRI	Brake opening completion signal		NET		External			
	16	X16	PU operation-external operation switching		External					
	17	X17	Load pattern selection forward rotation reverse rotation boost		NET		External			
	18	X18	V/F swichover		NET		External			
	19	X19	Load torque high speed frequency		NET		External			
	20	X20	S-pattern acceleration/deceleration C switching terminal		NET		External			
	22	X22	Orientation command *1		NET		External			
	23	LX	Pre-excitation		NET		External			
	24	MRS	Output stop		Combined		External		Pr. 79 ≠ "7" Pr. 79 = "7" When the X12 signal is not assigned	
			PU operation interlock		External					
	25	STOP	Start self-holding selection		—		External			
	26	MC	Control mode swichover		NET		External			
	27	TL	Torque limit selection		NET		External			
	28	X28	Start time tuning		NET		External			
	37	X37	Traverse function selection		NET		External			
	42	X42	Torque bias selection 1 *1		NET		External			
43	X43	Torque bias selection 2 *1		NET		External				
44	X44	P/PI control swichover		NET		External				

Control Location Selection		Pr. 338 Communication operation command source		0:NET			1:External			Remarks
		Pr. 339 Communication speed command source		0:NET	1: External	2: External	0:NET	1: External	2: External	
Selective functions Pr. 178 to Pr. 189 settings	50	SQ	Sequence start	Combined			External			
	60	STF	Forward rotation command	NET			External			
	61	STR	Reverse rotation command	NET			External			
	62	RES	Reset	External						
	63	PTC	PTC thermistor selection	External						
	64	X64	PID forward rotation action switchover	NET	External		NET	External		
	65	X65	PU/NET operation switchover	External						
	66	X66	NET/external operation switchover	External						
	67	X67	Command source switchover	External						
	68	NP	Conditional position pulse train sign *1	External						
	69	CLR	Conditional position droop pulse clear *1	External						
	70	X70	DC feeding operation permission	NET			External			
71	X71	DC feeding cancel	NET			External				

*1 Available only when used with the FR-A7AP.

[Table explanation]

External Only external terminal input control is valid.

NET Only network control is valid.

Combined Either external terminal input control or network control is valid.

- Both external terminal input control and network control are invalid.

Compensation External terminal input control is only valid if Pr. 28 Multi-speed input compensation is set to "1".



4.4 Communication EEPROM write selection (Pr. 342)

When parameters are written via communications, by default both volatile RAM and nonvolatile EEPROM contents are modified. Due to the limited write cycle lifetime of EEPROM memory, however, it may be desirable to modify only the contents of RAM when frequent parameter writes via communications are necessary.

Parameter Number	Name	Default Value	Setting Range	Description
342	Communication EEPROM write selection	0	0	Parameter values modified via communications are written to both EEPROM and RAM.
			1	Parameter values modified via communications are written only to RAM.

When frequently modifying parameter values via communications, change the value of *Pr. 342* to a “1” in order to write them only to RAM. Performing frequent parameter writes to EEPROM will shorten the lifetime of the component.

REMARKS

When *Pr. 342* is set to a value of “1” (write to RAM only), powering off the inverter will erase the changed parameter values. Therefore, the parameter values available when power is switched on again are those that were previously stored in EEPROM.

5 PROTOCOLS

The FR-A7N-XLT RS485 multiprotocol communication interface currently supports the following protocols:

- ▶ Johnson Controls, Inc. Metasys® N2
- ▶ Siemens FLN
- ▶ BACnet MS/TP
- ▶ Modbus RTU

Selection of which protocol is to be enabled is performed by DIP switch settings (refer to section 2.3.1).

This section will discuss topics that are specific to each of the available network selections.

5.1 Johnson Controls, Inc. Metasys N2

5.1.1 Node Addressing

Inverter parameter *Pr. 889* selects the Metasys N2 node address. Valid addresses are 1 – 255. **NOTE** that the factory default value for *Pr. 889* is “9999”, and must therefore be changed to a valid N2 node address, or an INVALID ADDRESS error indication will result.



5.1.2 Network Characteristics

No baud rate or parity, etc. configuration is necessary. The network characteristics are predetermined according to the Metasys N2 specification.

5.1.3 Object Summaries

The interface contains a predefined set of analog and binary I/O points used for configuring, controlling and monitoring the inverter. The interface supports analog input, analog output, binary input and binary output object types.

- **Analog input (AI)** objects are used for monitoring analog status items. AI objects support low alarm limits, low warning limits, high warning limits, high alarm limits and differential values. Change of state (COS), alarm and warning functions can also be enabled. An AI object will accept an override command, but will not change its actual value or indicate override active. A “multiplier value” is associated with the object, and is multiplied to the inverter’s associated raw data value to produce the floating-point AI value sent to the NCU (AI value = [inverter’s raw data value] X multiplier).
- **Analog output (AO)** objects are used for setting and monitoring analog control and configuration items. An AO value can be modified by issuing an override command. Issuing a release command will not cause the AO to automatically return to its pre-override value, nor will the AO automatically return to its pre-override value after a certain time period of no communication. A “multiplier value” is associated with the object, and the floating-point AO value is divided by this multiplier to produce the result that is passed on to the inverter’s associated register as raw data (inverter’s raw data value = [AO value] / multiplier).

- **Binary input (BI)** objects are used for monitoring discrete (digital) status items. BI objects support COS, alarm enabling and normal/alarm status indications. A BI object will accept an override command, but will not change its actual value or indicate override active. A “bit number” is associated with the object, and is used to determine the current state of the BI by inspecting the inverter register’s raw data value at the designated bit location. The register’s least-significant bit (LSB) is bit #0, and the most-significant bit (MSB) is bit #15.
- **Binary output (BO)** points are used for setting and monitoring discrete control and configuration items. A BO value can be modified by issuing an override command. Issuing a release command will not cause the BO to automatically return to its pre-override value, nor will the BO return to its pre-override value after a certain time period of no communication. With the exception of BO #1, a “bit number” is associated with the object, and is used by modifying the associated inverter register’s raw data value at the designated bit location. When the BO’s current state is set to “1” by the NCU, then the indicated bit is set. Similarly, when the BO’s current state is set to “0” by the NCU, then the indicated bit is cleared. The register’s least-significant bit (LSB) is bit #0, and the most-significant bit (MSB) is bit #15.

The Metasys device type for the FR-A7N-XLT is VND.



5.1.4 Supported Objects

The following table provides a listing of the Metasys objects supported by the interface. For all objects, an explanation is provided in the “Notes” column that details what inverter data (accessed as a Modbus holding register) the object maps to. For further information on these parameters, refer to the “Modbus Registers” section of the appropriate inverter *user’s manual (applied)*.

NPT ¹	NPA ²	Units	Point Description	Notes
AI	1	HZ	Output frequency	Inverter register 201, multiplier = 0.01
AI	2	A	Output current	Inverter register 202, multiplier = 0.01
AI	3	V	Output voltage	Inverter register 203, multiplier = 0.10
AI	4	HZ	Frequency setting	Inverter register 205, multiplier = 0.01
AI	5	RMIN	Running speed	Inverter register 206, multiplier = 1
AI	6	V	Converter output voltage	Inverter register 208, multiplier = 0.10
AI	7	PCT	Regenerative Brake duty	Inverter register 209, multiplier = 0.10
AI	8	PCT	Electric thermal relay function load factor	Inverter register 210, multiplier = 0.10
AI	9	A	Output current peak value	Inverter register 211, multiplier = 0.01
AI	10	V	Converter output peak value	Inverter register 212, multiplier = 0.10
AI	11	KW	Input power	Inverter register 213, multiplier = 0.01
AI	12	KW	Output Power	Inverter register 214, multiplier = 0.01
AI	13	-	Input terminal status	Inverter register 215, multiplier = 1
AI	14	-	Output terminal status	Inverter register 216, multiplier = 1
AI	15	PCT	Load Meter	Inverter register 217, multiplier = 0.10
AI	16	H	Cumulative energized time	Inverter register 220, multiplier = 1
AI	17	H	Actual operation time	Inverter register 223, multiplier = 1

NPT ¹	NPA ²	Units	Point Description	Notes
AI	18	PCT	Motor load factor	Inverter register 224, multiplier = 0.10
AI	19	KWH	Cumulative power	Inverter register 225, multiplier = 1
AI	20	-	Power saving effect	Inverter register 250, multiplier = 1
AI	21	-	Cumulative saving power	Inverter register 251, multiplier = 1
AI	22	PCT	PID set point	Inverter register 252, multiplier = 0.10
AI	23	PCT	PID measurement value	Inverter register 253, multiplier = 0.10
AI	24	PCT	PID deviation value	Inverter register 254, multiplier = 0.10
BI	1	--	Inverter communications	0 = card is not communicating with the inverter 1 = card is communicating with the inverter
BI	2	--	Running	Inverter register 9, bit 0 0 = stopped 1 = running
BI	3	--	Forward/Stop Status	Inverter register 9, bit 1 0 = not running forward 1 = running forward
BI	4	--	Reverse/Stop Status	Inverter register 9, bit 2 0 = not running reverse 1 = running reverse
BI	5	--	SU Terminal Status	Inverter register 9, bit 3 0 = off 1 = on
BI	6	--	OL Terminal Status	Inverter register 9, bit 4 0 = off 1 = on



NPT ¹	NPA ²	Units	Point Description	Notes
BI	7	--	IPF Terminal Status	Inverter register 9, bit 5 0 = off 1 = on
BI	8	--	FU Terminal Status	Inverter register 9, bit 6 0 = off 1 = on
BI	9	--	Alarm Output	Inverter register 9, bit 7 0 = no alarm 1 = alarm
AO	1	--	Operation Mode	Inverter register 10, multiplier = 1
AO	2	HZ	Frequency command	Inverter register 14, multiplier = 0.01
AO	3	--	Alarm Code ³	Inverter register 501, multiplier = 1
AO	4	HZ	Minimum frequency	Inverter register 1002, multiplier = 0.01
AO	5	SEC	Acceleration time	Inverter register 1007, multiplier = 0.10
AO	6	SEC	Deceleration time	Inverter register 1008, multiplier = 0.10
AO	7	HZ	Frequency jump A ⁴	Inverter register 1031, multiplier = 0.01
AO	8	HZ	Frequency jump B ⁴	Inverter register 1032, multiplier = 0.01
AO	9	PCT	PID set point ⁴	Inverter register 1133, multiplier = 0.01
BO	1	--	Reset command	Inverter register 2 0 = No inverter reset issued 1 = Inverter reset issued
BO	2	--	Command Forward/Stop	Inverter register 9, bit 1 0 = stop 1 = run forward

NPT ¹	NPA ²	Units	Point Description	Notes
BO	3	--	Command Reverse/Stop	Inverter register 9, bit 2 0 = stop 1 = run reverse
BO	4	--	Command AU Terminal	Inverter register 9, bit 8 0 = off 1 = on
BO	5	--	Command RL Terminal	Inverter register 9, bit 5 0 = off 1 = on
BO	6	--	Command RM Terminal	Inverter register 9, bit 4 0 = off 1 = on
BO	7	--	Command RH Terminal	Inverter register 9, bit 3 0 = off 1 = on
BO	8	--	Command RT Terminal	Inverter register 9, bit 7 0 = off 1 = on
BO	9	--	Command MRS Terminal	Inverter register 9, bit 10 0 = off 1 = on

[NOTE 1] NPT = Network Point Type

[NOTE 2] NPA = Network Point Address

[NOTE 3] The inverter's "alarm code" is defined as an analog output object due to the fact that not only can it be monitored, but writing any data value to this location in the inverter will also batch-clear the alarm history.

[NOTE 4] For these objects, a keypad-entry value of "9999" equates to a communication value of "655.35".



5.2 Siemens FLN

5.2.1 Node Addressing

Inverter parameter *Pr. 889* selects the FLN node address. Valid addresses are 0 – 98. **NOTE** that the factory default value for *Pr. 889* is “9999”, and must therefore be changed to a valid FLN node address, or an INVALID ADDRESS error indication will result.

5.2.2 Network Characteristics

No baud rate or parity, etc. configuration is necessary. The network characteristics are predetermined according to the FLN specification.

5.2.3 Supported Subpoints

The interface contains a predefined set of FLN subpoints used for configuring, controlling and monitoring the inverter. Refer to the following table for details.

Point #	Point Type	Subpoint Name	Factory Default	Units	Slope	Intercept	On Text	Off Text
01	LAO	ADDRESS	0	-	1	0	-	-
02	LAO	APPLICATION	2741	-	1	0	-	-
03	LDI	ASD COMM	NO	-	1	0	YES	NO
04	LDI	RUNNING	STOP	-	1	0	RUN	STOP
05	LDI	FWD.STOP	STOP	-	1	0	FWD	STOP
06	LDI	REV.STOP	STOP	-	1	0	REV	STOP
07	LDI	SU TERM	OFF	-	1	0	ON	OFF
08	LDI	OL TERM	OFF	-	1	0	ON	OFF
09	LDI	IPF TERM	OFF	-	1	0	ON	OFF
10	LDI	FU TERM	OFF	-	1	0	ON	OFF
11	LDI	ALARM OUTPUT	-	-	1	0	ALARM	-
12	LAI	FREQ OUTPUT	0	HZ	0.01	0	-	-
13	LAI	OUTPUT CUR	0	A	0.01	0	-	-
14	LAI	OUTPUT VOLT	0	V	0.1	0	-	-
15	LAI	FREQ SET	0	HZ	0.01	0	-	-
16	LAI	RUN SPEED	0	RMIN	1	0	-	-
17	LAI	CON OUT VOLT	0	V	0.1	0	-	-
18	LAI	REGEN BRAKE	0	PCT	0.1	0	-	-



Point #	Point Type	Subpoint Name	Factory Default	Units	Slope	Intercept	On Text	Off Text
19	LAI	ELEC LOAD	0	PCT	0.1	0	-	-
20	LAO	OVRD TIME	1	HRS	1	0	-	-
21	LAI	OUT CUR PEAK	0	A	0.01	0	-	-
22	LAI	CON OUT PEAK	0	V	0.1	0	-	-
23	LAI	IN POWER	0	KW	0.01	0	-	-
24	LAI	OUT POWER	0	KW	0.01	0	-	-
25	LAI	IN TER STAT	0	-	1	0	-	-
26	LAI	OUT TER STAT	0	-	1	0	-	-
27	LAI	LOAD METER	0	PCT	0.1	0	-	-
28	LAI	ENER TIME	0	H	1	0	-	-
29	LDO	DAY.NGT	DAY	-	1	0	NIGHT	DAY
30	LAI	OPER TIME	0	H	1	0	-	-
31	LAI	MOTOR LOAD	0	PCT	0.1	0	-	-
32	LAI	POWER	0	KWH	1	0	-	-
33	LAI	POWER SAVE	0	-	1	0	-	-
34	LAI	SAVE POWER	0	-	1	0	-	-
35	LAI	PID SET MON	0	PCT	0.1	0	-	-
36	LAI	PID MEA VAL	0	PCT	0.1	0	-	-
37	LAI	PID DEV VAL	0	PCT	0.1	0	-	-
38	LDO	RESET CMD	-	-	1	0	RESET	-
39	LDO	FWD.STOP CMD	STOP	-	1	0	FWD	STOP
40	LDO	REV.STOP CMD	STOP	-	1	0	REV	STOP

Point #	Point Type	Subpoint Name	Factory Default	Units	Slope	Intercept	On Text	Off Text
41	LDO	AU TERM CMD	OFF	-	1	0	ON	OFF
42	LDO	RL TERM CMD	OFF	-	1	0	ON	OFF
43	LDO	RM TERM CMD	OFF	-	1	0	ON	OFF
44	LDO	RH TERM CMD	OFF	-	1	0	ON	OFF
45	LDO	RT TERM CMD	OFF	-	1	0	ON	OFF
46	LDO	MRS TERM CMD	OFF	-	1	0	ON	OFF
47	LAO	OPER MODE	0	-	1	0	-	-
48	LAO	FREQ CMD	0	HZ	0.01	0	-	-
49	LAO	ALARM CODE	0	-	1	0	-	-
50	LAO	MIN FREQ	0	HZ	0.01	0	-	-
51	LAO	ACCEL TIME	5.0	SEC	0.1	0	-	-
52	LAO	DECEL TIME	5.0	SEC	0.1	0	-	-
53	LAO	FREQ JUMP A	327.67	HZ	0.01	0	-	-
54	LAO	FREQ JUMP B	327.67	HZ	0.01	0	-	-
55	LAO	PID SET CMD	327.67	PCT	0.01	0	-	-
99	LAO	ERROR STATUS	0	-	1	0	-	-

Notes:

- Points not listed are not used in this application.
- All points have the same value for English units and SI units.



5.2.4 Subpoint Details

This section provides a brief overview of each subpoint, including any notable behavior or settings. In all cases where subpoints map directly to inverter data, an explanation is provided that details which inverter data (accessed as a Modbus holding register) the subpoint maps to. For further information on these parameters, refer to the “Modbus Registers” section of the appropriate inverter *user’s manual (applied)*.

1. ADDRESS

This is the FLN address of the inverter. It can be changed via the network or *Pr. 889 Free parameter 2*.

2. APPLICATION

This is the Application ID for FLN on this inverter. This ID is assigned by Siemens for each unique application, and correlates directly to a particular point list approved at the time of release.

3. ASD COMM

Option card -to- inverter communications health indicator. This point has a value of “YES” if the option card is successfully communicating with the inverter. Status points read from the interface should be disregarded whenever this point’s value is “NO”. The inverter’s RS-485 wiring, etc., should also be inspected in such a situation in order to identify the cause of the communication outage.

4. RUNNING

Indicates the status of the RUN output terminal function configured by *Pr. 190 RUN terminal function selection*. Corresponds to Modbus register 9, bit 0.

5. FWD.STOP

Indicates whether the inverter is running forward, or stopped. Corresponds to Modbus register 9, bit 1.

6. REV.STOP

Indicates whether the inverter is running reverse, or stopped. Corresponds to Modbus register 9, bit 2.

7. SU TERM

Indicates the status of the SU output terminal function configured by *Pr. 191 SU terminal function selection*. Corresponds to Modbus register 9, bit 3.

8. OL TERM

Indicates the status of the OL output terminal function configured by *Pr. 193 OL terminal function selection*. Corresponds to Modbus register 9, bit 4.

9. IPF TERM

Indicates the status of the IPF output terminal function configured by *Pr. 192 IPF terminal function selection*. Corresponds to Modbus register 9, bit 5.

10. FU TERM

Indicates the status of the FU output terminal function configured by *Pr. 194 FU terminal function selection*. Corresponds to Modbus register 9, bit 6.

11. ALARM OUTPUT

Indicates the status of the ABC1 output terminal function configured by *Pr. 195 ABC1 terminal function selection*. Corresponds to Modbus register 9, bit 7.

**12. FREQ OUTPUT**

The output frequency of the inverter in Hertz. Corresponds to Modbus register 201.

13. OUTPUT CUR

The output current of the inverter in Amps. Corresponds to Modbus register 202.

14. OUTPUT VOLT

The output voltage of the inverter in Volts. Corresponds to Modbus register 203.

15. FREQ SET

The frequency setting of the inverter in Hertz. Corresponds to Modbus register 205.

16. RUN SPEED

The running speed of the inverter in revolutions per minute. Corresponds to Modbus register 206.

17. CON OUT VOLT

Converter output voltage in Volts. Corresponds to Modbus register 208.

18. REGEN BRAKE

Regenerative brake duty in percent. Corresponds to Modbus register 209.

19. ELEC LOAD

Electric thermal relay function load factor in percent. Corresponds to Modbus register 210.

20. OVRD TIME

This is a mandatory FLN point required for compatibility with Siemens control systems. It has no effect in this application.

21. OUT CUR PEAK

Output current peak value in Amps. Corresponds to Modbus register 211.

22. CON OUT PEAK

Converter output voltage peak value in Volts. Corresponds to Modbus register 212.

23. IN POWER

Input power in kW. Corresponds to Modbus register 213.

24. OUT POWER

Output power in kW. Corresponds to Modbus register 214.

25. IN TER STAT

Input terminal status. Corresponds to Modbus register 215.

26. OUT TER STAT

Output terminal status. Corresponds to Modbus register 216.

27. LOAD METER

Load meter in percent. Corresponds to Modbus register 217.

**28. ENER TIME**

Cumulative energized time in hours. Corresponds to Modbus register 220.

29. DAY.NIGHT

This is a mandatory FLN point required for compatibility with Siemens control systems. It has no effect in this application.

30. OPER TIME

Actual operation time in hours. Corresponds to Modbus register 223.

31. MOTOR LOAD

Motor load factor in percent. Corresponds to Modbus register 224.

32. POWER

Cumulative power in kWh. Corresponds to Modbus register 225.

33. POWER SAVE

Power saving effect. Corresponds to Modbus register 250.

34. SAVE POWER

Cumulative saving power. Corresponds to Modbus register 251.

35. PID SET MON

PID set point in percent. Corresponds to Modbus register 252.

36. PID MEA VAL

PID measurement value in percent. Corresponds to Modbus register 253.

37. PID DEV VAL

PID deviation value in percent. Corresponds to Modbus register 254.

38. RESET CMD

Inverter fault reset command. Corresponds to Modbus register 2.

39. CMD FWD.STOP

Activates the STF input terminal function configured by *Pr. 178 STF terminal function selection*. Note that commanding this point is effective only when the inverter is configured for network start/stop control. Corresponds to Modbus register 9, bit 1.

40. CMD REV.STOP

Activates the STR input terminal function configured by *Pr. 179 STR terminal function selection*. Note that commanding this point is effective only when the inverter is configured for network start/stop control. Corresponds to Modbus register 9, bit 2.

41. AU TERM CMD

Activates the AU input terminal function configured by *Pr. 184 AU terminal function selection*. Note that commanding this point is effective only when the inverter is configured for network start/stop control. Corresponds to Modbus register 9, bit 8.

**42. RL TERM CMD**

Activates the RL input terminal function configured by *Pr. 180 RL terminal function selection*. Note that commanding this point is effective only when the inverter is configured for network start/stop control. Corresponds to Modbus register 9, bit 5.

43. RM TERM CMD

Activates the RM input terminal function configured by *Pr. 181 RM terminal function selection*. Note that commanding this point is effective only when the inverter is configured for network start/stop control. Corresponds to Modbus register 9, bit 4.

44. RH TERM CMD

Activates the RH input terminal function configured by *Pr. 182 RH terminal function selection*. Note that commanding this point is effective only when the inverter is configured for network start/stop control. Corresponds to Modbus register 9, bit 3.

45. RT TERM CMD

Activates the RT input terminal function configured by *Pr. 183 RT terminal function selection*. Note that commanding this point is effective only when the inverter is configured for network start/stop control. Corresponds to Modbus register 9, bit 7.

46. MRS TERM CMD

Activates the MRS input terminal function configured by *Pr. 187 MRS terminal function selection*. Note that commanding this point is effective only when the inverter is configured for network start/stop control. Corresponds to Modbus register 9, bit 10.

47. OPER MODE

Inverter operation mode. Corresponds to Modbus register 10.

48. FREQ CMD

The frequency command of the inverter in Hertz. Note that commanding this point is effective only when the inverter is configured for network frequency control. Corresponds to Modbus register 14.

49. ALARM CODE

Alarm history 1. Writing any value to this point will clear the alarm history of the inverter. Corresponds to Modbus register 501.

50. MIN FREQ

The inverter's minimum allowable frequency in Hertz. Corresponds to Modbus register 1002.

51. ACCEL TIME

Acceleration time in seconds. Corresponds to Modbus register 1007.

52. DECEL TIME

Deceleration time in seconds. Corresponds to Modbus register 1008.

53. FREQ JUMP A

Sets the lower limit of the jump frequency for area #1. An FLN object value of 327.67 for this point corresponds to an internal inverter value of 9999 (disabled). Corresponds to Modbus register 1031.

**54. FREQ JUMP B**

Sets the upper limit of the jump frequency for area #1. An FLN object value of 327.67 for this point corresponds to an internal inverter value of 9999 (disabled). Corresponds to Modbus register 1032.

55. PID SET CMD

PID set point. An FLN object value of 327.67 for this point corresponds to an internal inverter value of 9999 (use terminal 2 input). Note that commanding this point is effective only when the inverter is in the PU operation or PU/external combined mode. Corresponds to Modbus register 1133.

99. ERROR STATUS

This is a mandatory FLN point required for compatibility with Siemens control systems. It has no effect in this application.

5.3 BACnet MS/TP

5.3.1 Station Addressing

Inverter parameter *Pr. 888* selects the device instance number and *Pr. 889* selects the station address. Valid addresses are 0 – 127. **NOTE** that the factory default value for *Pr. 889* is “9999”, and must therefore be changed to a valid station address, or an INVALID ADDRESS error indication will result.

5.3.2 Network Characteristics

The network baud rate can be set via DIP switches to any supported value except 4800 baud. Refer to section 2.3.2. All other network characteristics are predetermined according to the BACnet specification.

5.3.3 Protocol Implementation Conformance Statement

BACnet Protocol

Date:	January 29, 2008
Vendor Name:	ICC, Inc.
Product Name:	FR-A7N-XLT
Product Model Number:	FR-A7N-XLT
Applications Software Version:	V2.000
Firmware Revision:	V2.000
BACnet Protocol Revision:	2

**Product Description:**

The FR-A7N-XLT is a RS485 multiprotocol communication plug-in option for Mitsubishi 700-series inverters. This product supports native BACnet, connecting directly to the MS/TP LAN using baud rates of 9600, 19200, and 38400.

BACnet Standard Device Profile (Annex L):

- BACnet Operator Workstation (B-OWS)
- BACnet Building Controller (B-BC)
- BACnet Advanced Application Controller (B-AAC)
- BACnet Application Specific Controller (B-ASC)
- BACnet Smart Sensor (B-SS)
- BACnet Smart Actuator (B-SA)

BACnet Interoperability Building Blocks Supported (Annex K):

- Data Sharing – ReadProperty-B (DS-RP-B)
- Data Sharing – ReadPropertyMultiple-B (DS-RPM-B)
- Data Sharing – WriteProperty-B (DS-WP-B)
- Data Sharing – WritePropertyMultiple-B (DS-WPM-B)
- Device Management – Dynamic Device Binding-B (DM-DDB-B)
- Device Management – Dynamic Object Binding-B (DM-DOB-B)
- Device Management – DeviceCommunicationControl-B (DM-DCC-B)
- Device Management – ReinitializeDevice-B (DM-RD-B)

Segmentation Capability:

None

- Segmented requests supported Window Size _____
- Segmented responses supported Window Size _____

Standard Object Types Supported:

See “Object Types/Property Support Table” for object details.

Data Link Layer Options:

- BACnet IP, (Annex J)
- BACnet IP, (Annex J), Foreign Device
- ISO 8802-3, Ethernet (Clause 7)
- ANSI/ATA 878.1, 2.5 Mb. ARCNET (Clause 8)
- ANSI/ATA 878.1, RS-485 ARCNET (Clause 8), baud rate(s) _____
- MS/TP master (Clause 9), baud rate(s): 9600, 19200, 38400
- MS/TP slave (Clause 9), baud rate(s): _____
- Point-To-Point, EIA 232 (Clause 10), baud rate(s): _____
- Point-To-Point, modem, (Clause 10), baud rate(s): _____
- LonTalk, (Clause 11), medium: _____
- Other: _____

**Device Address Binding:**

Is static device binding supported? (This is currently for two-way communication with MS/TP slaves and certain other devices.) Yes No

Networking Options:

- Router, Clause 6 - List all routing configurations
- Annex H, BACnet Tunneling Router over IP
- BACnet/IP Broadcast Management Device (BBMD)
Does the BBMD support registrations by Foreign Devices? Yes No

Character Sets Supported:

Indicating support for multiple character sets does not imply that they can all be supported simultaneously.

- ANSI X3.4 IBM™/Microsoft™ DBCS ISO 8859-1
- ISO 10646 (UCS-2) ISO 10646 (UCS-4) JIS C 6226

If this product is a communication gateway, describe the types of non-BACnet equipment/networks(s) that the gateway supports:

The FR-A7N-XLT option card mounts directly onto the Mitsubishi 700 series inverter's control board, and communicates to the inverter via its built-in RS485 communication port. The card uses Modbus RTU to communicate with the inverter.



Object Types/Property Support Table

The following table summarizes the Object Types/Properties supported.

Property	Object Type				
	Device	Binary Input	Binary Output	Analog Input	Analog Output
Object Identifier	R	R	R	R	R
Object Name	R	R	R	R	R
Object Type	R	R	R	R	R
System Status	R				
Vendor Name	R				
Vendor Identifier	R				
Model Name	R				
Firmware Revision	R				
App Software Revision	R				
Protocol Version	R				
Protocol Revision	R				
Services Supported	R				
Object Types Supported	R				
Object List	R				
Max APDU Length	R				
Segmentation Support	R				

Property	Object Type				
	Device	Binary Input	Binary Output	Analog Input	Analog Output
APDU Timeout	R				
Number APDU Retries	R				
Max Master	R				
Max Info Frames	R				
Device Address Binding	R				
Database Revision	R				
Present Value		R	W	R	W
Status Flags		R	R	R	R
Event State		R	R	R	R
Reliability					
Out-of-Service		R	R	R	R
Units				R	R
Priority Array			R		R
Relinquish Default			R		R
Polarity		R	R		
Active Text		R	R		
Inactive Text		R	R		

R – readable using BACnet services

W – readable and writable using BACnet services

5.3.4 Supported Objects

The following table provides a listing of the BACnet objects supported by the interface. Note that these objects are static, i.e. objects cannot be created, deleted, or modified. Only the present value property may be modified for either Analog or Binary Outputs. All other properties are read-only. For all objects, an explanation is provided in the “Notes” column that details which inverter data (accessed as a Modbus holding register) the object maps to. For further information on these parameters, refer to the “Modbus Registers” section of the appropriate inverter *user’s manual (applied)*.

Object Type	Object Instance	Units	Point Description	Notes
AI	1	HZ	Output frequency	Inverter register 201, multiplier = 0.01
AI	2	A	Output current	Inverter register 202, multiplier = 0.01
AI	3	V	Output voltage	Inverter register 203, multiplier = 0.10
AI	4	HZ	Frequency setting	Inverter register 205, multiplier = 0.01
AI	5	RMIN	Running speed	Inverter register 206, multiplier = 1
AI	6	V	Converter output voltage	Inverter register 208, multiplier = 0.10
AI	7	PCT	Regenerative Brake duty	Inverter register 209, multiplier = 0.10
AI	8	PCT	Electric thermal relay function load factor	Inverter register 210, multiplier = 0.10
AI	9	A	Output current peak value	Inverter register 211, multiplier = 0.01
AI	10	V	Converter output peak value	Inverter register 212, multiplier = 0.10
AI	11	KW	Input power	Inverter register 213, multiplier = 0.01

Object Type	Object Instance	Units	Point Description	Notes
AI	12	KW	Output Power	Inverter register 214, multiplier = 0.01
AI	13	-	Input terminal status	Inverter register 215, multiplier = 1
AI	14	-	Output terminal status	Inverter register 216, multiplier = 1
AI	15	PCT	Load Meter	Inverter register 217, multiplier = 0.10
AI	16	H	Cumulative energized time	Inverter register 220, multiplier = 1
AI	17	H	Actual operation time	Inverter register 223, multiplier = 1
AI	18	PCT	Motor load factor	Inverter register 224, multiplier = 0.10
AI	19	KWH	Cumulative power	Inverter register 225, multiplier = 1
AI	20	-	Power saving effect	Inverter register 250, multiplier = 1
AI	21	-	Cumulative saving power	Inverter register 251, multiplier = 1
AI	22	PCT	PID set point	Inverter register 252, multiplier = 0.10
AI	23	PCT	PID measurement value	Inverter register 253, multiplier = 0.10
AI	24	PCT	PID deviation value	Inverter register 254, multiplier = 0.10
BI	1	--	Running	Inverter register 9, bit 0 0 = stopped 1 = running
BI	2	--	Forward/Stop Status	Inverter register 9, bit 1 0 = not running forward 1 = running forward
BI	3	--	Reverse/Stop Status	Inverter register 9, bit 2 0 = not running reverse 1 = running reverse



Object Type	Object Instance	Units	Point Description	Notes
BI	4	--	SU Terminal Status	Inverter register 9, bit 3 0 = off 1 = on
BI	5	--	OL Terminal Status	Inverter register 9, bit 4 0 = off 1 = on
BI	6	--	IPF Terminal Status	Inverter register 9, bit 5 0 = off 1 = on
BI	7	--	FU Terminal Status	Inverter register 9, bit 6 0 = off 1 = on
BI	8	--	Alarm Output	Inverter register 9, bit 7 0 = no alarm 1 = alarm
AO	1	--	Operation Mode	Inverter register 10, multiplier = 1
AO	2	HZ	Frequency command	Inverter register 14, multiplier = 0.01
AO	3	--	Alarm Code ¹	Inverter register 501, multiplier = 1
AO	4	HZ	Minimum frequency	Inverter register 1002, multiplier = 0.01
AO	5	SEC	Acceleration time	Inverter register 1007, multiplier = 0.10
AO	6	SEC	Deceleration time	Inverter register 1008, multiplier = 0.10
AO	7	HZ	Frequency jump A ²	Inverter register 1031, multiplier = 0.01

Object Type	Object Instance	Units	Point Description	Notes
AO	8	HZ	Frequency jump B ²	Inverter register 1032, multiplier = 0.01
AO	9	PCT	PID set point ²	Inverter register 1133, multiplier = 0.01
BO	1	--	Reset command	Inverter register 2 0 = No inverter reset issued 1 = Inverter reset issued
BO	2	--	Command Forward/Stop	Inverter register 9, bit 1 0 = stop 1 = run forward
BO	3	--	Command Reverse/Stop	Inverter register 9, bit 2 0 = stop 1 = run reverse
BO	4	--	Command AU Terminal	Inverter register 9, bit 8 0 = off 1 = on
BO	5	--	Command RL Terminal	Inverter register 9, bit 5 0 = off 1 = on
BO	6	--	Command RM Terminal	Inverter register 9, bit 4 0 = off 1 = on



Object Type	Object Instance	Units	Point Description	Notes
BO	7	--	Command RH Terminal	Inverter register 9, bit 3 0 = off 1 = on
BO	8	--	Command RT Terminal	Inverter register 9, bit 7 0 = off 1 = on
BO	9	--	Command MRS Terminal	Inverter register 9, bit 10 0 = off 1 = on

[NOTE 1] The inverter's "alarm code" is defined as an analog output object due to the fact that not only can it be monitored, but writing any data value to this location in the inverter will also batch-clear the alarm history.

[NOTE 2] For these objects, a keypad-entry value of "9999" equates to a communication value of "655.35"

5.4 Modbus RTU

5.4.1 Node Addressing

Inverter parameter *Pr. 889* selects the Modbus node address. Valid addresses are 1 – 247. **NOTE** that the factory default value for *Pr. 889* is “9999”, and must therefore be changed to a valid Modbus node address, or an INVALID ADDRESS error indication will result.

5.4.2 Network Characteristics

The network baud rate, parity and stop bits can be set via DIP switches. Refer to sections 2.3.2 and 2.3.3. Note that the Modbus external network characteristics set by the DIP switches are unrelated to inverter parameters *Pr. 332 RS-485 communication speed* and *Pr. 334 RS-485 communication parity check selection*, which affect only the communication between the inverter's control board CPU and the FR-A7N-XLT interface.

5.4.3 Supported Functions

The interface can act as a Modbus RTU slave according to the *Modicon Modbus Protocol Reference Guide (PI-MBUS-300 Rev. J)*. Supported Modbus functions are indicated in the following table. Broadcasts (address field=0) for functions 5, 6, 15 and 16 are supported.



Function Code	Function
1	Read coils
2	Read input status
3	Read multiple registers
4	Read input registers
5	Write coil
6	Write single register
8	Diagnostics (subfunction 0 only)
15	Force multiple coils
16	Write multiple registers

5.4.4 Register Addressing

To access an inverter parameter, simply access the corresponding Modbus register (holding or input) as documented in the “Modbus Registers” section of the appropriate inverter *user’s manual (applied)*.

5.4.5 Coil & Discrete Input Mappings

The Modbus slave implementation provides read/write support for coils (0X references) and read-only support for discrete inputs (1X references). These will collectively be referred to from here on out as simply “discretes”. Accessing discretes does not reference any new physical data: discretes are simply indexes into various bits of Modbus registers. What this means is that when a discrete is accessed, it is resolved by the interface into a specific register, and a specific bit within that register. The pattern of discrete-to-register/bit relationships can be described as follows:

Discrete 1...16 map to register #1, bit0...bit15 (bit0=LSB, bit15=MSB)
Discrete 17...32 map to register #2, bit0...bit15, and so on.

Arithmetically, the discrete-to-register/bit relationship can be described as follows: For any given discrete, the register in which that discrete resides can be determined by:

$$register = \left\lfloor \frac{discrete + 15}{16} \right\rfloor \quad \dots Equation 1$$

Where the bracket symbols “ $\lfloor \]$ ” indicate the “floor” function, which means that any fractional result (or “remainder”) is to be discarded, with only the integer value being retained.

Also, for any given discrete, the targeted bit in the register in which that discrete resides can be determined by:



$$bit = (discrete - 1) \% 16$$

...Equation 2

Where “discrete” $\in [1 \dots 65535]$, “bit” $\in [0 \dots 15]$, and “%” is the modulus operator, which means that any fractional result (or “remainder”) is to be retained, with the integer value being discarded (i.e. it is the opposite of the “floor” function).

From these equations, it can be seen that the largest register number that can be accessed via this discrete-to-register mapping method is 4096 (which contains discrete #65535).

For clarity, let’s use Equation 1 and Equation 2 in a calculation example. Say, for instance, that we are going to read coil #34. Using Equation 1, we can determine that coil #34 resides in register #3, as $\lfloor 3.0625 \rfloor = \lfloor 3 \text{ r}1 \rfloor = 3$. Then, using Equation 2, we can determine that the bit within register #3 that coil #34 targets is $(34-1)\%16 = 1$, as $33\%16 = \text{mod}(3 \text{ r}1) = 1$. Therefore, reading coil #34 will return the value of register #3, bit #1.

Note that this discrete-to-register/bit relationship holds true regardless of whether or not register #3 even exists on the inverter. If register #3 does not exist, then a Modbus exception will be returned. Either way, coil #34 will always access register #3, bit #1.

6 TROUBLESHOOTING

Although by no means exhaustive, the following table provides possible causes behind some of the most common errors experienced when using the FR-A7N-XLT interface.

Problem	Symptom	Solution
No communications between FR-A7N-XLT and the inverter	The FR-A7N-XLT's "ASD" TX and RX LEDs are blinking slowly, sporadically, or not at all	<ul style="list-style-type: none"> • Check connections and orientation of the #10621 cable between the FR-A7N-XLT and the inverter. • Confirm that the inverter's station ID (<i>Pr. 331</i>), baud rate (<i>Pr. 332</i>) and parity (<i>Pr. 334</i>) are set to 1, 38400 and even, respectively. • Confirm that the inverter's RS-485 protocol selection is set to Modbus (<i>Pr. 549</i> = 1). • Confirm that the network station address (<i>Pr. 889</i>) setting is valid for your chosen network ("STATUS" LED will also be flashing.)
No communications between the network and the FR-A7N-XLT	The FR-A7N-XLT's "NETWORK" TX and RX LEDs are blinking slowly, sporadically, or not at all	<ul style="list-style-type: none"> • Check connections and orientation of wiring between the network and the FR-A7N-XLT. • Confirm that the 2-wire/4-wire DIP switches are both in the same position and appropriate for your chosen network. • Confirm that the protocol, baud rate, and parity DIP switch settings (where applicable) match your network configuration.



Problem	Symptom	Solution
Firmware-generated error	"STATUS" LED is flashing. The number of times the "STATUS" LED flashes indicates an error code.	<ul style="list-style-type: none">• 1 flash indicates an invalid network address programmed into inverter parameter <i>Pr. 889</i>.• 2 flashes indicate an invalid protocol selected on the FR-A7N-XLT's DIP switches.• 3 flashes indicate an option board hardware or firmware error. Please contact ICC for further assistance.• 4 flashes indicate an invalid baud rate selected when in BACnet mode.
Unable to control the inverter via network communications	Cannot write to command parameters via network communications, or writing to these parameters has no apparent effect	Set the inverter to NET mode. The inverter will reject all command and parameter write requests from the network if it is not in NET mode.

REVISIONS

Date	Manual Number	Details
Feb. 2007	10638-1.000-000	Initial release
May 2007	10638-1.100-000	Minor changes & text corrections
Feb. 2008	10638-2.000-000	Add BACnet MS/TP protocol support

ICC

INDUSTRIAL CONTROL COMMUNICATIONS, INC.

Madison Office

1600 Aspen Commons, Suite 210
Middleton, WI USA 53562-4720
Tel: [608] 831-1255 Fax: [608] 831-2045

<http://www.iccdesigns.com>



Collaborative Automation
Partner Program



Houston Office

12300 Dundee Court, Suite 212
Cypress, TX USA 77429-8364

Printed in U.S.A