



KELE POWERTRAK POWER MONITORING INTERFACE PT-9000 SERIES

DESCRIPTION

The **PT-9000 Series Power Monitoring Interface** monitors numerous power system parameters for local display and/or remote connection to a BAS or other data acquisition equipment. Any three or single-phase 50/60 Hertz electrical system from 120-600V can be monitored by the **PT-9000 Series** without the need for potential transformers. Higher voltage systems such as 5 kV or 15 kV services can also be monitored using potential transformers. The **PT-9000 Series** is available for use with 5A or 0.333V current transformers. Options include a current transformer shorting assembly and a digital LCD display.

Furnished in a NEMA 1 hinged-cover enclosure with external mounting feet and conduit knockouts on all sides, the **PT-9000 Series** is simple to install. Setup of the **PT-9000 Series** is easily accomplished with a selector switch and DIP switches. A truly unique feature of the **PT-9000 Series** is its ability to identify and electronically correct wiring problems such as reversed CT polarities or improper phasing of voltages with CT's.

FEATURES

- *Auto-corrects for wiring errors*
- *Three-phase (Wye or Delta) or single-phase systems*
- *Voltage selector switch (120-600V)*
- *Accepts 5A or 0.333V CTs*
- *Low-voltage alarm contact*
- *Two 4-20 mA outputs*
- *Pulse output for kWh with selectable pulse rate*
- *Optional two-line LCD display*
- *Optional unique CT shorting assembly*
- *Easily installed enclosure with external mounting feet*
- *Optional LonWorks, Modbus, and Metasys communications*



PT-9500-D
(Shown with optional display)



APPLICATION

Remote (Outputs) and Local (Display) Monitoring

<i>KWH</i>	<i>Total KW</i>
<i>Window KW</i>	<i>Peak window KW</i>
<i>Total KVA</i>	<i>Total power factor (PF)</i>
<i>True RMS voltage</i>	<i>True RMS current</i>

Local (Display) Monitoring - Each Phase

<i>True RMS voltage</i>
<i>True RMS current</i>
<i>kW (Wye systems)</i>
<i>kVA (Wye systems)</i>
<i>Power factor (Wye systems)</i>

All parameters can be monitored over a single pair of wires with a communications module installed.

SPECIFICATIONS

Supply Voltage	120-600 VAC , 50/60 Hz	Analog Output	Two externally powered 4-20 mA signals selectable for total kW, window kW, peak window kW, total power factor, total kVA, RMS current, or RMS voltage
System Type	Three-phase (Wye or Delta), or single-phase	Maximum Load	725Ω each output @ 24 VDC
Input	0-5A or 0-0.333V	Display	** Optional LCD, two lines, 16 characters/line
CT Burden	0.75 VA maximum (5A input)	Accuracy	0.75% of FS (kW, kVA, V, A) ± 0.03 PF (0.4 to 1.0 PF)
Monitored Voltage		Operating Temperature	32° to 122°F (0° to 50°C)
Line to Line:	120 to 600 VAC	Operating Humidity	5 to 95% (non-condensing)
Line to Line with potential transformer:	601 to 32000 VAC	Dimensions	12"H x 10"W x 4"D (30.5 x 25.4 x 10.2 cm)
Monitored Current	5 to 6000 Amps with current transformer	NEMA 3R	20"H x 16"W x 6"D (50.8 x 40.6 x 15.2 cm)
PT Burden	4.8 VA maximum	Weight	12 lb (5.5 kg)
Internal Fusing	0.5A, 600V (KLK-0.5)	NEMA 3R	43 lb (20 kg)
Pulse Output	Pulsed contact closure for kWh solid-state relay, 50 VAC/VDC maximum, 100 mA maximum	Approvals	UL and cUL listed, File #E161500 Certified to LonMark Interoperability Guidelines version 3.1
Pulse Rate	Four selectable kWh per pulse rates, 50% duty cycle	Warranty	18 months
Maximum Pulse Rate	Five pulses per second		
Digital Output	Maintained contact closure for low-voltage alarm; 50 VAC/VDC, 100 mA maximum		

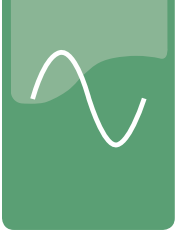

CONFIGURATION

DIP Switches

Setting the DIP switches according to system requirements is suggested before applying power to the **PT-9000 Series**. However, it is not necessary to remove power from the **PT-9000 Series** in order to make changes to the DIP switch settings.

A1 - A2: Define the power system type. Set these switches to match the type of system that is to be monitored. Select from three-phase Wye or Delta and single-phase two- or three-wire systems.

A3 - A8: Define the low-voltage alarm threshold. Select an appropriate value for the system voltage that is monitored. For Delta systems, low voltage is measured line-to-line. For Wye and single-phase systems, low voltage is measured line-to-neutral. Select from alarm threshold values ranging from 51-540V.

B1 - B2: Define the kWh per pulse value. Set these switches to obtain an optimum pulse rate that can be read by the BAS controller or data acquisition equipment. Select from 10, 1, 0.1, and 0.01 kWh per pulse values.

B3 - B5: Define mA loop #2 signal type. Set these switches for the power parameter to be represented by this 4-20 mA output. Select from seven different parameters: Total kW, Window kW, Peak Window kW, Total kVA, Total Power Factor, True RMS Voltage*, True RMS Current*.

B6 - B8: Define mA loop #1 signal type. Set these switches for the power parameter to be represented by this 4-20 mA output. Select from seven different parameters: Total kW, Window kW, Peak Window kW, Total kVA, Total Power Factor, True RMS Voltage*, True RMS Current*.

C1 - C5: Define the current transformer ratio. Set switches to match the primary current rating of the current transformers connected to the PT-9000 Series. Select from CT primaries ranging from 50 to 6000.

* Voltage and current outputs are the average of the three-phase true RMS values.

System Voltage Select Switch

Set the SYSTEM VOLTAGE SELECT switch to the correct line-to-line system voltage (or potential transformer secondary voltage, if used) connected to the PT-9000 Series. If the actual system voltage is greater than the selector switch setting, the over voltage LED will flash, and the PT-9000 Series will cycle on and off to protect itself from over voltage. If this occurs, turn the selector switch to the correct system voltage setting.

Auto-Configuration

After all wiring connections are completed, the DIP switches are set correctly, the voltage selector switch is set to the correct system voltage, and the electrical system is energized, the **PT-9000 Series** can be auto-configured. To initiate the autoconfiguring system, press the AUTO-CONFIG button. The **PT-9000 Series** will examine the current and voltage waveforms for correct phasing and CT polarity. During the auto-configuring process, the Volts/Amps phasing LEDs and CT reverse polarity LEDs will light in sequence. When the process is completed only one of the Volts/Amps phasing LEDs will be lighted, indicating the actual phasing between the voltage and current inputs to the **PT-9000 Series**. A lighted CT polarity LED indicates that the corresponding CT is installed or wired backwards giving a reverse polarity. A correctly wired PT-9000 Series will be indicated by all CT polarity LEDs extinguished and the left-most Volts/Amps phasing LED lighted. Should any of the other phasing or CT polarity LEDs be lighted, the **PT-9000 Series** will electronically fix the wiring errors and provide correct and accurate outputs. No time-consuming troubleshooting or wire swapping is required.

Manual Configuration

If the auto-configuring system is unable to determine the correct wiring configuration, the **PT-9000 Series** will enter the manual configuration mode, and the manual config yellow LED will light. If this occurs, try initiating the auto-configuring system again, otherwise proceed with manual configuration. The electrical system load should be relatively constant during the manual configuration procedure. To manually configure the PT-9000 Series, set the DIP switches so that one of the 4-20 mA outputs represents Total KW. Connect a meter set to read DC milliamps to this output, or if the **PT-9000 Series** has the LCD display option, set one of the display lines to read Total kW. Next, press the manual config CT polarity button (CT POL) to scan through the different CT polarity combinations. Each time, record the reading of the Total kW display or mA output. Allow the reading to stabilize before recording it. After reviewing all of the CT polarity combinations, press the manual config V-A MATCH button and repeat the process of scanning through the CT polarity combinations. After trying all possible combinations of V-A match and CT polarity, the correct configuration is the one producing the highest value of kW on the display or the highest mA reading on the meter. Manually set the **PT-9000 Series** to the correct configuration using the CT POL and V-A MATCH push buttons.



KELE POWERTRAK POWER MONITORING INTERFACE PT-9000 SERIES

POWER MONITORING & PROTECTION

17

WIRING - THREE-PHASE POWERTRAK APPLICATION

CAUTION: Lethal voltages may be present across the secondary terminals of all current transformers. Keep these terminals shorted or connected to the transducer.

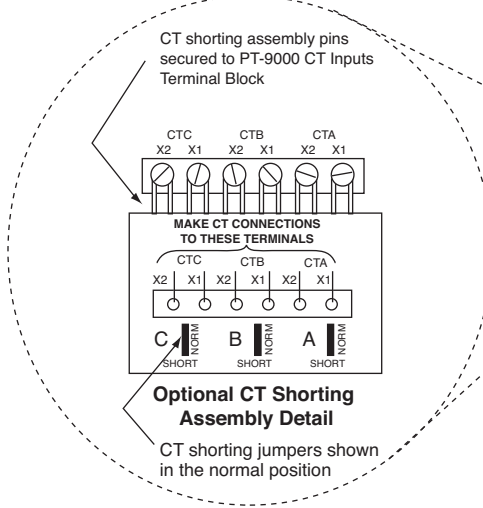
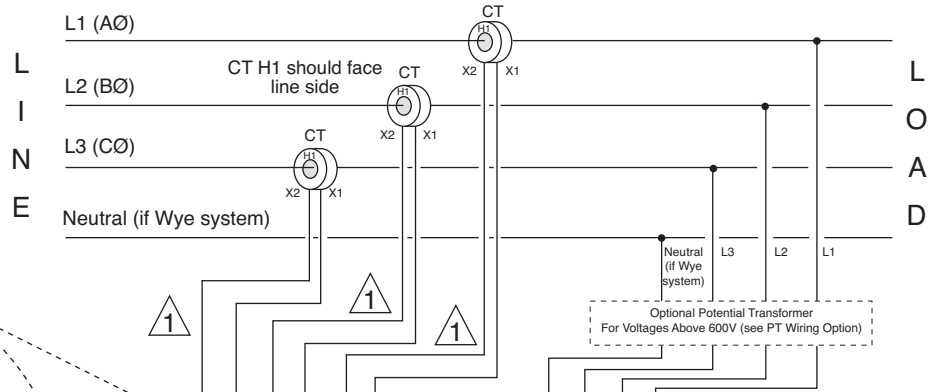

Optional Cover-Mounted LCD Display Detail*

*Manually scroll individual lines of display using the cover-mounted push buttons, to select different power system parameters.

1 When using the **SCT Series** current transformers with the **PT-9300**, recommended wiring is a twisted shielded pair for each CT to avoid noise pick-up. Ground shield wire at **PT-9300** ground lug only.

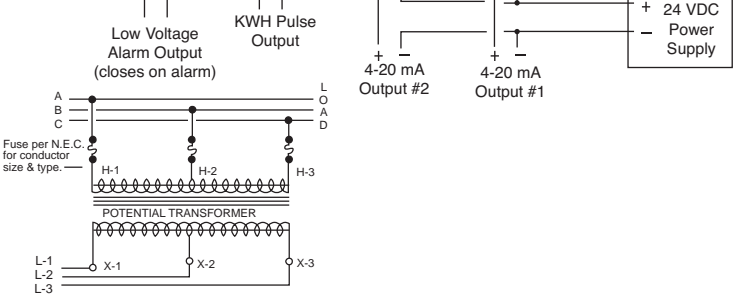
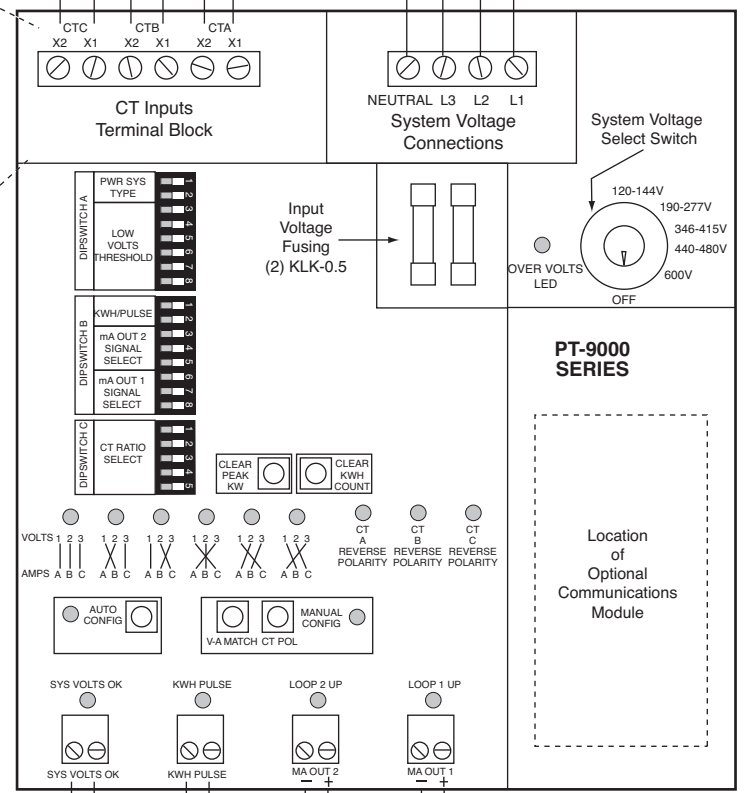

PT Wiring Option
(for systems greater than 600V)
Connection option using one open Delta 3PT3 three-phase potential transformer with 120 VAC secondary.

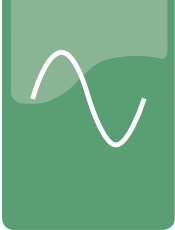

POWER MONITORING & PROTECTION

KELE POWERTRAK POWER MONITORING INTERFACE

PT-9000 SERIES

POWER MONITORING & PROTECTION

17

WIRING - SINGLE-PHASE POWERTRAK APPLICATIONS

1 When using the **SCT Series** current transformers with the **PT-9300**, recommended wiring is a twisted shielded pair for each CT to avoid noise pick-up. Ground shield wire at **PT-9300** ground lug only.

★ Make CT connections to terminal strip on optional CT shorting assembly if present. See Wiring - Three-Phase PowerTrak Application.

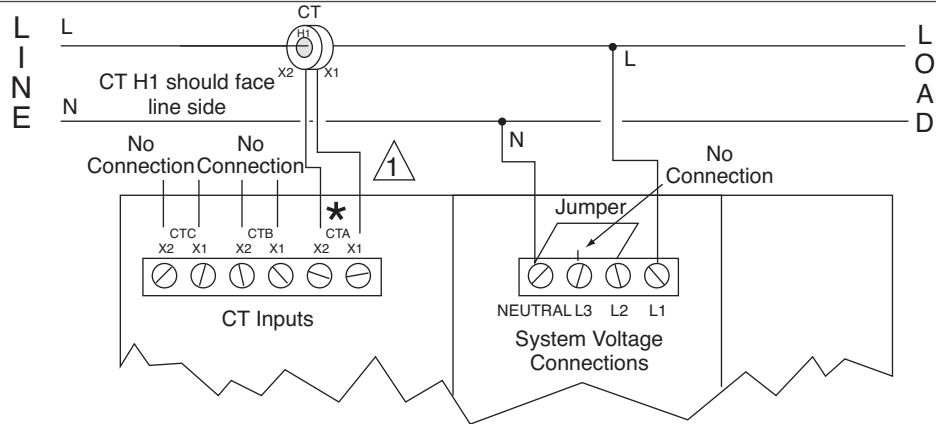

Single-Phase Two-Wire Systems

1 When using the **SCT Series** current transformers with the **PT-9300**, recommended wiring is a twisted shielded pair for each CT to avoid noise pick-up. Ground shield wire at **PT-9300** ground lug only.

★ Make CT connections to terminal strip on optional CT shorting assembly if present. See Wiring - Three-Phase PowerTrak Application.

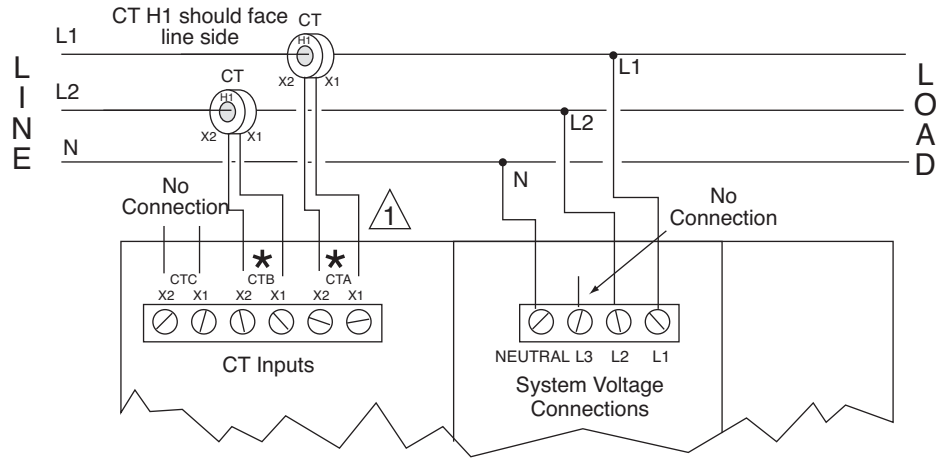

Single-Phase Three-Wire Systems

ORDERING INFORMATION

MODEL	DESCRIPTION
PT-9500	PowerTrak power monitoring interface, 5A CT input
PT-9300	PowerTrak power monitoring interface, 0.333V CT input
OPTIONS	
D	LCD display, cover-mounted for local monitoring
S	CT shorting assembly (not necessary for PT-9300)
3R	PowerTrak mounted in a NEMA 3R enclosure

PT-9500 - D - S **Example: PT-9500-D-S** PowerTrak with LCD display and CT shorting assembly

RELATED PRODUCTS

		PAGE
A-L12AR	Cylinder lock kit	228
PT-NT4-BAC	BACnet MSTP communications module	767
PT-NT4-M	Modbus communications module	767
PT-NT4-N2	Metasys® communications module	767
PT-NTL-10	LonWorks communications module	767