

Overview

The BAPI Repeater receives the 418 MHz RF signal from one or more wireless temperature or humidity transmitters which have a range of 100 feet. The Repeater re-transmits the signal at 900 Mhz to a distance of 1,000 feet to a BAPI 900 MHz Receiver.

The 900 MHz Receiver then outputs the values to any Analog Output Module through an RS485 four-wire bus. The Analog Output Module converts the signal to an analog voltage, current or resistance for the controller. The 900 MHz Receiver can accommodate up to 127 different Analog Output Modules. The Repeater is surface, snaptrack or din rail mountable with an attached antenna and a 79" extendable antenna.

Product Identification

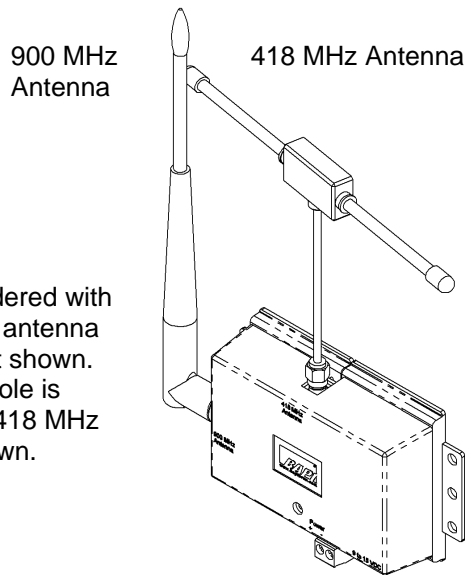

Figure 1: 418MHz to 900MHz repeater

Note: May be ordered with a 900MHz dipole antenna on a 79" wire, not shown. The 900 MHz dipole is smaller than the 418 MHz dipole that is shown.

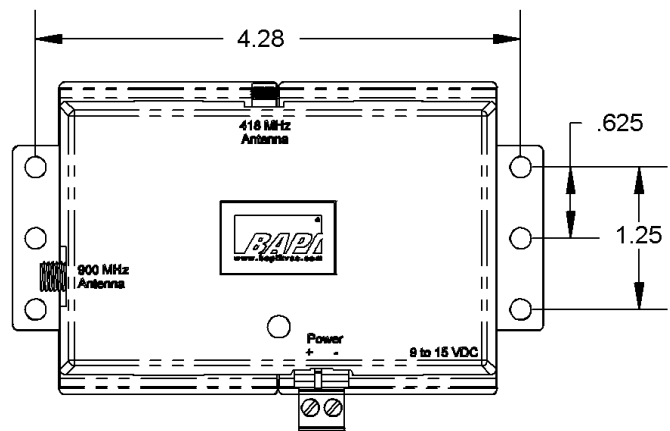

Figure 2: 418MHz to 900MHz repeater dimensions

Tools and Materials

#2 Phillips Screwdriver, Drill

Mounting

Mount the repeater within 100 feet (30.5 meters) of the 418 MHz transmitters. Mount the 418 MHz antenna to a nonconductive surface or just dangle in the air. Secure the antenna cable so that no mechanical stress is presented to the repeater.

The 900 MHz antenna is shipped loose. Connect the antenna by turning the antenna nut onto the repeater's fitting. The repeater should be within 1000 feet (305 meters) of the 900 MHz receiver.

The repeater can be mounted using Snaptrack, DIN Rail or onto a surface. Use #4 screws to secure the repeater to its mounting surface.

If the repeater is placed inside a metal enclosure, mount the antennas outside the enclosure.

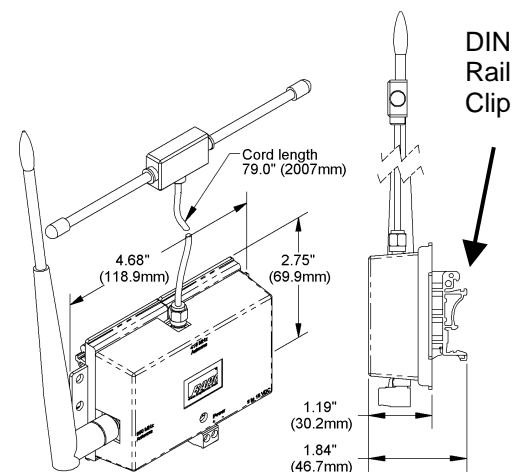

Specifications subject to change without notice.



Terminations

The repeater is powered by 9 to 15 VDC. Connect the terminal labeled "-" to the power supply's ground. Connect the terminal labeled "+" to the positive power supply terminal.

Diagnostics

Possible Problems:

Power LED does not light

Transmissions not getting through

Possible Solutions:

Make sure that power is plugged in and turned on.

Make sure that transmitters and receiver are powered up and operating properly.
Make sure that repeater is within range of transmitters and receiver.

Specifications

Supply Power: 9 to 15 VDC

Power Consumption: 150 mA max.

Inputs: 418MHz

Output: 900MHz at 100mW

Environmental Operation Range:

Temp: 0° to 60°C

Humidity: 5% to 95% RH non-condensing

Material: ABS Plastic

Material Rating: UL94, V-0

Specifications subject to change without notice.