

## CD50 LOW LEAKAGE CONTROL DAMPER EXTRUDED ALUMINUM

### STANDARD CONSTRUCTION

#### FRAME

5" x 1" x 6063T5 extruded aluminum hat channel with .125" minimum wall thickness (127 x 25 x 3.2). Low profile, 5" x 1/2" (127 x 13) top and bottom frames on dampers 12" (305) high and less. Mounting flanges on both sides of frame.

#### BLADES

6" (152) wide, 6063T5 heavy gage extruded aluminum, airfoil shape.

#### LINKAGE

Concealed in frame.

#### AXLES

1/2" (13) plated steel hex.

#### BEARINGS

Molded synthetic.

#### SEALS

Blade Edge – Extruded Ruskiprene (TPR) for -72°F to +275°F (-58°C to +135°C).

Jamb – Flexible metal compressible type.

#### CONTROL SHAFT

Removable, 1/2" (13) diameter shaft extends 6" (152) beyond frame.

#### FINISH

Mill.

#### MINIMUM SIZE

Single blade, parallel action – 6"w x 5"h (152 x 127).

Two blade, opposed action – 6"w x 9"h (152 x 229).

#### MAXIMUM SIZE

Single section – 60"w x 72"h (1524 x 1829).

Multiple section assembly – Unlimited size.

Dampers larger than the single section maximum are furnished in an assembly of 48" x 72" (1219 x 1829) or less equal sized individual sections. Tee flange option maximum 60" x 72" (1524 x 1829) on multiple sections.

### FEATURES

Ruskin's premier damper for medium pressure commercial and industrial HVAC systems offers the lowest leakage available with a standard, commercial built damper. The CD50 was the first AMCA-licensed low leakage damper and bears the AMCA Air Leakage Seal.

Linkage is concealed in the frame out of the airstream for low maintenance and reduced air turbulence. Hexagonal axles ensure a positive lock with blades. An easily replaceable, double-edge blade seal features an inflatable pocket that assists in blade seal.

**NOTE:** Dimensions shown in parenthesis ( ) indicate millimeters.

\*Units furnished approximately 1/4" (6) smaller than given opening dimensions.

\*\*Jackshaft standard on multiple section dampers.

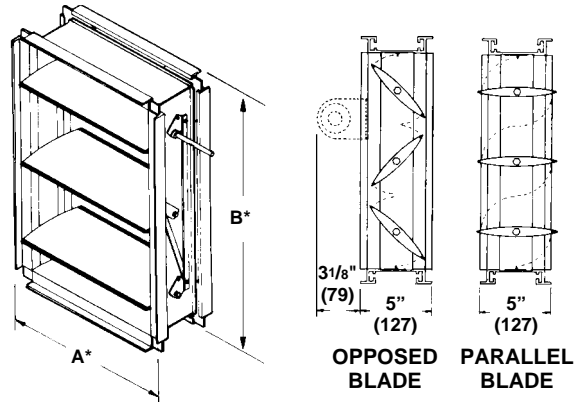

Ruskin Company certifies that the CD50 shown here- in is licensed to bear the AMCA Seal. The ratings shown are based on tests and procedures performed in accordance with AMCA Publication 511 and comply with the requirements of the AMCA Certified Ratings Program. The AMCA International Certified Ratings Seal applies to Air Performance and Air Leakage.

### FRAME CONSTRUCTION OPTIONS

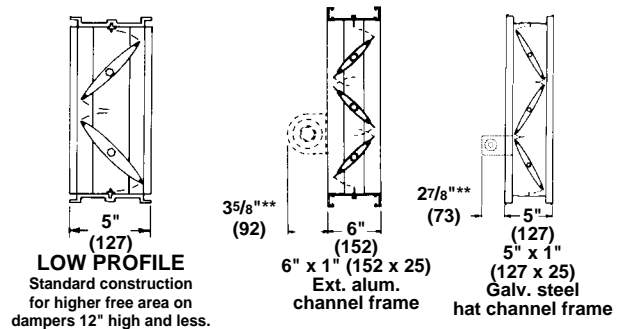

### VARIATIONS

Variations to the CD50 basic design are available at additional cost. They include:

- Anodize and special finishes
- Pneumatic or electric actuators
- SP100 Switch Package
- Front or rear or flange frame
- 5" x 1" x 16 gage (127 x 25 x 1.6) galvanized steel hat channel frame
- 6" x 1" x 6063T5 (152 x 25 x 3.2) extruded aluminum hat channel frame
- Face and bypass mixing damper assemblies

| QTY.           | OPENING DIM. |    | FRAME STYLE |                 |                | VARIATIONS |
|----------------|--------------|----|-------------|-----------------|----------------|------------|
|                | A*           | B* | STD.        | Front Flange FF | Rear Flange RF |            |
|                |              |    |             |                 |                |            |
|                |              |    |             |                 |                |            |
|                |              |    |             |                 |                |            |
|                |              |    |             |                 |                |            |
| JOB CONTRACTOR |              |    | LOCATION    |                 |                |            |

# CD50 PERFORMANCE DATA

## CD50 PRESSURE LIMITATIONS

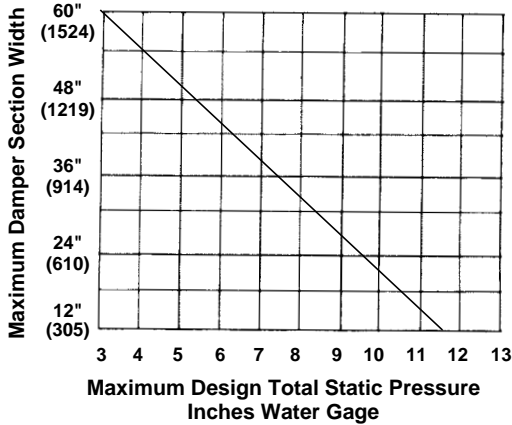

The CD50 may be used in systems with total pressures exceeding 3.5" by reducing damper section width as indicated. Example: Maximum design total pressure of 8.5" w.g. would require CD50 damper with maximum section width of 36" (914).

Pressure limitations shown above allow maximum blade deflection of 1/180 of span on 60" (1524) damper widths. Deflections in other damper widths (less than 48" [1219]) at higher pressures shown will result in blade deflection substantially less than 1/180 of span.



Ruskin Company certifies that the CD50 shown herein is licensed to bear the AMCA Seal. The ratings shown are based on tests and procedures performed in accordance with AMCA Publication 511 and comply with the requirements of the AMCA Certified Ratings Program. The AMCA International Certified Ratings Seal applies to Air Performance and Air Leakage.

| DAMPER WIDTH (INCHES) | 1 IN. W.G. | 4 IN. W.G. | 8 IN. W.G. |
|-----------------------|------------|------------|------------|
| 12" (305)             | I          | I          | I          |
| 24" (610)             | I          | I          | I          |
| 36" (914)             | I          | I          | I          |
| 48" (1219)            | I          | I          | NA         |
| 60" (1524)            | I          | I          | NA         |

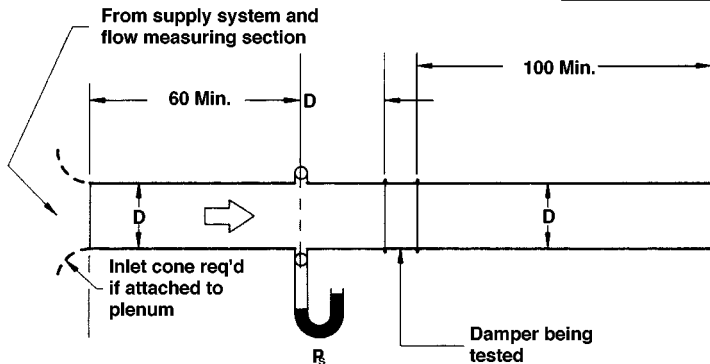

### AMCA STANDARD 500

FIGURE 5.3 DAMPER TEST SETUP WITH INLET AND OUTLET DUCTS

- |                          |                           |
|--------------------------|---------------------------|
| <b>Class I =</b>         | <b>Class II =</b>         |
| 4 CFM Sq. Ft. @ 1" w.g.; | 10 CFM Sq. Ft. @ 1" w.g.; |
| 8 CFM Sq. Ft. @ 4" w.g.; | 20 CFM Sq. Ft. @ 4" w.g.; |
| 11 CFM Sq. Ft. @ 8" w.g. | 28 CFM Sq. Ft. @ 8" w.g.  |

## VELOCITY VS. PRESSURE DROP

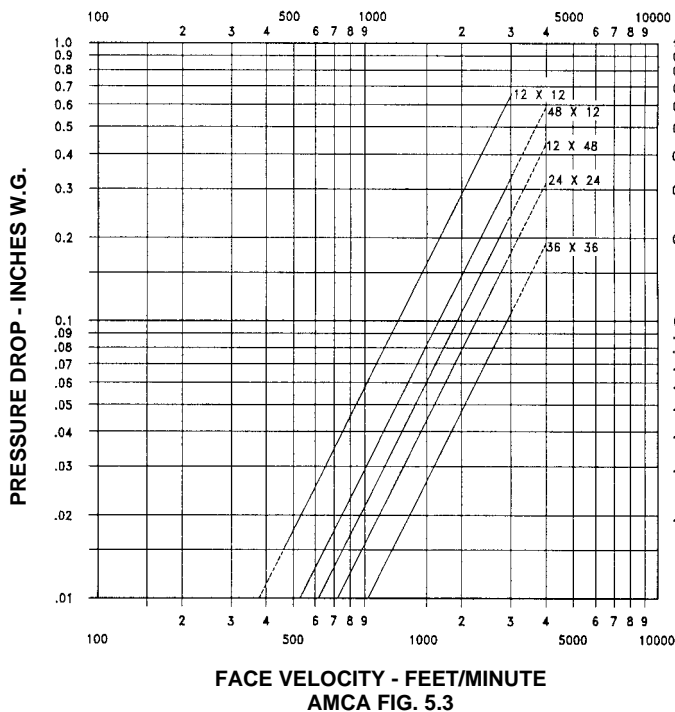

FACE VELOCITY - FEET/MINUTE  
AMCA FIG. 5.3

CD50 sizes 12 x 12, 24 x 24, 48 x 12, 12 x 48, 36 x 36  
(305 x 305, 610 x 610, 1219 x 305, 305 x 1219, 914 x 914)

All data corrected to represent standard air at a density of 0.075 lbs/ft<sup>3</sup>.

Leakage testing conducted in accordance with AMCA Standard 500-D-98. Torque applied holding damper closed, 5 in. lbs./sq. ft. on opposed blade dampers and 7 in. lbs./sq. ft. on parallel blade dampers. Air leakage is based on operation between 50°F to 104°F. All data corrected to represent standard air density 0.075 lbs/ft<sup>3</sup>.

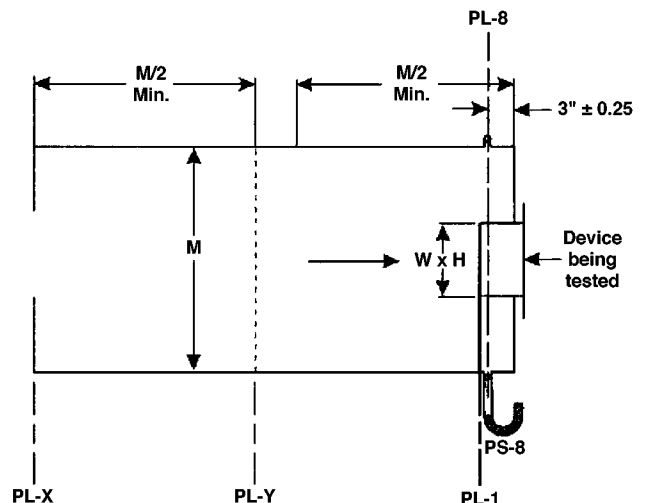

ALTERNATE MOUNT B (LEAKAGE TEST ONLY)  
FIGURE 5.5 TEST DEVICE SETUP WITH INLET CHAMBER

## CD50 SUGGESTED SPECIFICATION

Furnish and install, at locations shown on plans, or in accordance with schedules, Low leakage dampers shall meet the following minimum construction standards: Frames shall be 5" x 1" x .125" (minimum thickness) 6063T5 extruded aluminum hat channel with hat mounting flanges on both sides of the frame. Each corner shall be reinforced with two die formed internal braces and machine staked for maximum rigidity. Blades shall be airfoil type extruded aluminum (maximum 6" depth) with integral structural reinforcing tube running full length of each blade.

Blade edge seals shall be extruded double edge design with inflatable pocket which enables air pressure from either direction to assist in blade to blade seal off. Blades seals shall be mechanically

locked in extruded blade slots, yet shall be easily replaceable in field. Adhesive or clip-on type blade seals are not acceptable. Bearings shall be non-corrosive molded synthetic. Axles shall be hexagonal (round not acceptable) to provide positive locking connection to blades and linkage. Linkage shall be concealed in frame. Submittal must include leakage, maximum air flow and maximum pressure ratings based on AMCA Publication 500. Damper shall be tested and certified in accordance with AMCA 511 for Air Performance and Air Leakage. Damper widths from 12" to 60" wide shall not leak any greater than 8 cfm sq. ft. @ 4" w.g. Dampers shall be in all respects equivalent to Ruskin Model CD50.

## CD50 PERFORMANCE DATA

The actual pressure drop through a damper is the result of many factors. The formula and area factor table below may be used to estimate pressure drop for a CD50 of a given size, with straight duct runs upstream and downstream, as in AMCA Figure 5.3.

### CD50 FREE AREA

| Height Dim. B | Dimension A – Width In Inches |           |           |           |           |           |           |           |            |            |            |            |            |            |
|---------------|-------------------------------|-----------|-----------|-----------|-----------|-----------|-----------|-----------|------------|------------|------------|------------|------------|------------|
|               | 8" (203)                      | 12" (305) | 16" (406) | 20" (508) | 24" (610) | 28" (711) | 32" (813) | 36" (914) | 40" (1016) | 44" (1118) | 48" (1219) | 52" (1321) | 56" (1422) | 60" (1524) |
| 8" (203)      | 0.18                          | 0.32      | 0.45      | 0.59      | 0.72      | 0.86      | 0.99      | 1.13      | 1.27       | 1.40       | 1.54       | 1.67       | 1.81       | 1.94       |
| 10" (254)     | 0.24                          | 0.42      | 0.59      | 0.77      | 0.95      | 1.12      | 1.30      | 1.48      | 1.66       | 1.83       | 2.01       | 2.19       | 2.36       | 2.54       |
| 12" (305)     | 0.31                          | 0.55      | 0.78      | 1.01      | 1.24      | 1.48      | 1.71      | 1.94      | 2.17       | 2.41       | 2.64       | 2.87       | 3.10       | 3.34       |
| 14" (356)     | 0.35                          | 0.61      | 0.87      | 1.13      | 1.39      | 1.66      | 1.92      | 2.18      | 2.44       | 2.70       | 2.96       | 3.22       | 3.48       | 3.74       |
| 16" (406)     | 0.41                          | 0.71      | 1.01      | 1.31      | 1.62      | 1.92      | 2.22      | 2.52      | 2.83       | 3.13       | 3.43       | 3.73       | 4.04       | 4.34       |
| 18" (457)     | 0.48                          | 0.83      | 1.20      | 1.56      | 1.91      | 2.27      | 2.63      | 2.99      | 3.35       | 3.70       | 4.06       | 4.42       | 4.78       | 5.14       |
| 20" (508)     | 0.56                          | 0.97      | 1.38      | 1.80      | 2.21      | 2.62      | 3.04      | 3.45      | 3.87       | 4.28       | 4.69       | 5.11       | 5.52       | 5.93       |
| 24" (610)     | 0.69                          | 1.20      | 1.71      | 2.22      | 2.73      | 3.24      | 3.75      | 4.26      | 4.77       | 5.28       | 5.80       | 6.31       | 6.82       | 7.33       |
| 28" (711)     | 0.82                          | 1.43      | 2.03      | 2.64      | 3.25      | 3.86      | 4.47      | 5.07      | 5.68       | 6.29       | 6.90       | 7.51       | 8.11       | 8.72       |
| 32" (813)     | 0.97                          | 1.69      | 2.41      | 3.12      | 3.84      | 4.56      | 5.28      | 6.00      | 6.72       | 7.44       | 8.16       | 8.88       | 9.60       | 10.32      |
| 36" (914)     | 1.10                          | 1.91      | 2.73      | 3.55      | 4.36      | 5.18      | 6.00      | 6.81      | 7.63       | 8.45       | 9.26       | 10.00      | 10.89      | 11.71      |
| 40" (1016)    | 1.23                          | 2.14      | 3.06      | 3.97      | 4.88      | 5.80      | 6.71      | 7.62      | 8.54       | 9.45       | 10.36      | 11.28      | 12.19      | 13.11      |
| 44" (1118)    | 1.36                          | 2.37      | 3.38      | 4.39      | 5.40      | 6.41      | 7.42      | 8.43      | 9.45       | 10.46      | 11.47      | 12.48      | 13.49      | 14.50      |
| 48" (1219)    | 1.51                          | 2.63      | 3.75      | 4.87      | 6.00      | 7.12      | 8.24      | 9.36      | 10.48      | 11.61      | 12.73      | 13.85      | 14.97      | 16.09      |
| 52" (1321)    | 1.64                          | 2.86      | 4.08      | 5.30      | 6.52      | 7.73      | 8.95      | 10.17     | 11.39      | 12.61      | 13.83      | 15.05      | 16.27      | 17.49      |
| 56" (1422)    | 1.77                          | 3.09      | 4.40      | 5.72      | 7.03      | 8.35      | 9.67      | 10.98     | 12.30      | 13.62      | 14.93      | 16.25      | 17.57      | 18.88      |
| 60" (1524)    | 1.92                          | 3.35      | 4.77      | 6.20      | 7.63      | 9.06      | 10.48     | 11.91     | 13.34      | 14.77      | 16.19      | 17.62      | 19.05      | 20.48      |
| 64" (1626)    | 2.05                          | 3.57      | 5.10      | 6.62      | 8.15      | 9.67      | 11.20     | 12.72     | 14.25      | 15.77      | 17.30      | 18.82      | 20.35      | 21.87      |
| 68" (1727)    | 2.18                          | 3.80      | 5.42      | 7.05      | 8.67      | 10.29     | 11.91     | 13.53     | 15.16      | 16.78      | 18.40      | 20.02      | 21.64      | 23.27      |
| 72" (1829)    | 2.33                          | 4.06      | 5.80      | 7.53      | 9.26      | 10.99     | 12.73     | 14.46     | 16.19      | 17.93      | 19.66      | 21.39      | 23.13      | 24.86      |

### Formula

$$\Delta P = 2.18 \left[ \frac{\text{CFM}}{\text{AREA FACTOR}} - \text{Vel.} \right]^2$$

4005

$\Delta P$  = Pressure drop in inches w.g.  
 Vel. = Duct Velocity in feet per minute  
 CFM = Duct area in sq. ft. x velocity in FPM

# CD50 TYPICAL INSTALLATION

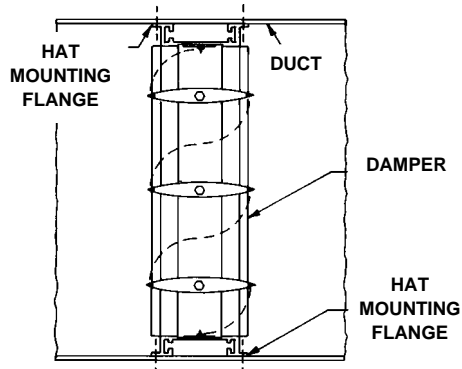

## TYPICAL MODEL CD50 INSTALLATION

Two 1/2" hat mounting flanges are provided around damper perimeter for easy and economical installation. Damper may be quickly installed in ductwork by use of sheet metal screws. Dampers must be installed square and free from racking. Actuator must be installed on the linkage side of the damper. Opposed blade dampers must be operated from a power blade.

For complete assembly and installation instructions details refer to the Ruskin "Standard Multiple Section Control Damper Details" and "Induct Mount Control Dampers Installation Instructions."

### BRACING OF MULTIPLE SECTION DAMPER ASSEMBLIES

The CD50 is intended to be self supporting only in its largest single section size. Multiple section damper assemblies may require bracing to support the weight of the assembly and to hold against the system pressure. Ruskin recommends appropriate bracing to support the damper horizontally at least once for every 8' of damper width and bracing of vertical assemblies and higher system pressures may require more bracing.

The CD50 is designed for installation with blades running horizontally. Installation with blades running vertically is not recommended. Contact Ruskin for vertical blade installations.

### CD50 SOUND RATINGS

| Damper Size | Damper Full Open |    | Damper 75% Open |    | Damper 50% Open |    | Damper 25% Open |    |
|-------------|------------------|----|-----------------|----|-----------------|----|-----------------|----|
|             | CFM              | NC | CFM             | NC | CFM             | NC | CFM             | NC |
| 12 x 12     | 2000             | 17 | 1500            | 11 | 1000            | 11 | 500             | *  |
|             | 3000             | 28 | 2250            | 22 | 1500            | 19 | 750             | *  |
|             | 4000             | 35 | 3000            | 29 | 2000            | 24 | 1000            | *  |
| 18 x 18     | 2250             | 17 | 1688            | 10 | 1125            | 21 | 563             | *  |
|             | 4500             | 33 | 3375            | 26 | 2250            | 32 | 1125            | *  |
|             | 6750             | 43 | 5063            | 37 | 3375            | 40 | 1688            | 15 |
| 24 x 24     | 4000             | 11 | 3000            | 10 | 2000            | 26 | 1000            | *  |
|             | 8000             | 32 | 6000            | 30 | 4000            | 38 | 2000            | 21 |
|             | 12000            | 43 | 9000            | 42 | 6000            | 46 | 3000            | 31 |

NC = Noise criteria in Decibels is based on 10db room effect and 10db of room attenuation.

\* = Less than 10 NC

See ASHRAE Handbook (1977 Fundamentals, Chapter 7) for explanation of NC Ratings.

# **RUSKIN**<sup>®</sup>

3900 Dr. Greaves Rd.  
Kansas City, MO 64030  
(816) 761-7476  
FAX (816) 765-8955  
www.ruskin.com