

CD46 VERY LOW LEAKAGE CONTROL DAMPER Galvanized Steel

STANDARD CONSTRUCTION

FRAME

5" x 1" x 16 gage (127 x 25 x 1.6) galvanized steel hat channel reinforced with corner braces for structural strength equal to 13 gage (2.28) channel frames. Low profile 3 1/2" x 3/8" x 16 gage (89 x 10 x 1.5) galvanized steel channel top and bottom frame on dampers under 13" (330) high.

BLADES

6" (152) wide, 16 (1.6) gage galvanized steel blades approximately 6" (152) on center. Parallel or opposed action.

SEALS

Blade seal is PVC coated polyester fabric mechanically locked into blade edge. Jamb is flexible metal, compression type.

BEARINGS

Synthetic.

LINKAGE

Concealed in frame.

AXLES

1/2" (13) plated steel hex.

CONTROL SHAFT

6" (152) x 1/2" (13) diameter. Outboard support bearing supplied with all single section dampers for field mounted actuators. Factory-installed jackshaft supplied with all multiple section dampers.

FINISH

Mill.

MAXIMUM SIZE

Single section – 48"w x 72"h (1219 x 1829).
Multiple section assembly – Unlimited size.

MINIMUM SIZE

Single blade – 5"w x 5"h (127 x 127).

Two blades, parallel or opposed action, exposed linkage – 8"w x 14"h (203 x 356).

Two blades, parallel or opposed action, concealed linkage – 5"w x 8"h (127 x 203).

TEMPERATURE LIMITS

-25°F (-32°C) minimum and +180°F (+83°C) maximum.

Maximum section width varies with static pressure. Consult Ruskin if application involves pressures in excess of 2.5 inches w.g. or air velocities in excess of 2000 fpm.

NOTE: Dimensions shown in parenthesis () indicate millimeters.

*Units furnished approximately 1/4" (6) smaller than given opening dimensions.

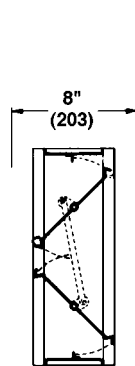
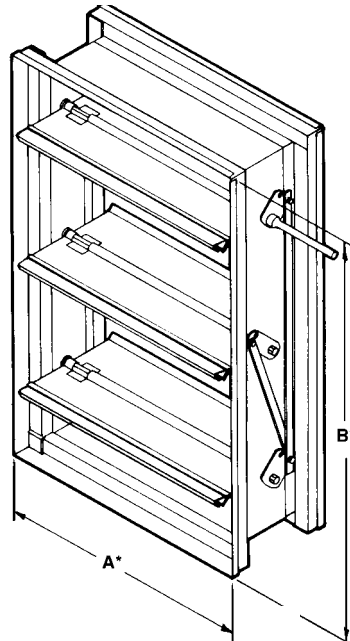

LOW PROFILE FRAME
(Opposed blade action depicted. For units under 12" [305] high.)

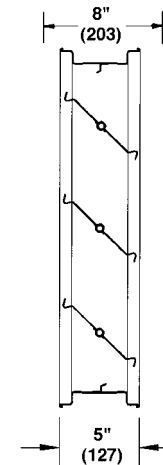

STANDARD FRAME
(Parallel blade action depicted.)

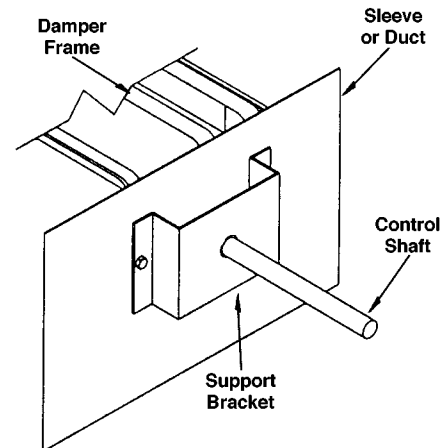

OUTBOARD SHAFT SUPPORT BRACKET

FEATURES

The CD46 offers sturdy, steel construction with interlocking frame design. Damper locks together without bolts, screws, or rivets that could shake loose. Frame corners are internally braced to reduce racking.

Axles positively lock to blades without screws or welds. Non-stick, noncorrosive bearings assure long life and ease of operation. Axles and bearings combine with a shake proof linkage for low maintenance operation.

When tested in accordance with AMCA Standard 500, the CD46 exhibits low leakage rates that meet the frequently specified, 10 cfm/sq. ft. at 4" w.g. or 1/2% maximum leakage level.

VARIATIONS AND ADDITIONAL OPTIONS

Variations to the CD46 basic design are available at additional cost. They include:

- Front and/or rear flanges. With or without bolt holes.
- Thrust bearings for vertical blade orientation (consult Ruskin before ordering).
- Factory-installed, pneumatic and electric actuators (specific information required with order).
- Ruskin frame mounted actuator bracket to simplify field installation of most actuators (specify actuator and action, i.e., N.O. or N.C., with order).
- SP100 Switch Package to remotely indicate damper blade position.

PERFORMANCE DATA

Damper Width	Maximum System Pressure	Maximum System Velocity	Leakage*	
			% of max. flow	CFM/sq. ft.
48"	2.5" w.g.	1500 fpm	0.36	3.7
36"	3.0" w.g.	1500 fpm	0.36	3.7
24"	4.0" w.g.	1500 fpm	0.39	4.8
12"	5.0" w.g.	1500 fpm	0.47	7.0

*Leakage information based on pressure differential of 1" w.g. tested per AMCA Publication 500.

The CD46 is structurally designed for velocities to 2000 fpm and above. Turbulence may produce objectionable noise in some conditions with velocities above 1500 fpm.

Dampers may tolerate higher pressures and velocities than those listed here. Conservative ratings are presented intentionally in an effort to avoid misapplication. Consult Ruskin when a damper is to be applied in conditions exceeding recommended maximums.